



ZHEJIANG NEWTON FLUID CONTROL CO.,LTD.

Headquarters (Wenzhou)

Zhiyi road,Lingxia industrial zone,Wuniu,Wenzhou,

Zhejiang, China.

Tel: 86-577-67978269

Fax:86-577-67376711

E-mail: vmv@vmv-valve.com

Shanghai R&D Center

Jiading District, Shanghai

Building 12A, No. 1818 Chengbei Road

Tel: 86-18057752663

E-mail: vmv8@vmv-valve.com

CE ISO TS EAC DNV
www.vmvvalve.com



Scan More Wonderful

www.vmvvalve.com

VMV®

2024 © Version and technical interpretation rights belong to Newton.Counteringing must be investigated!

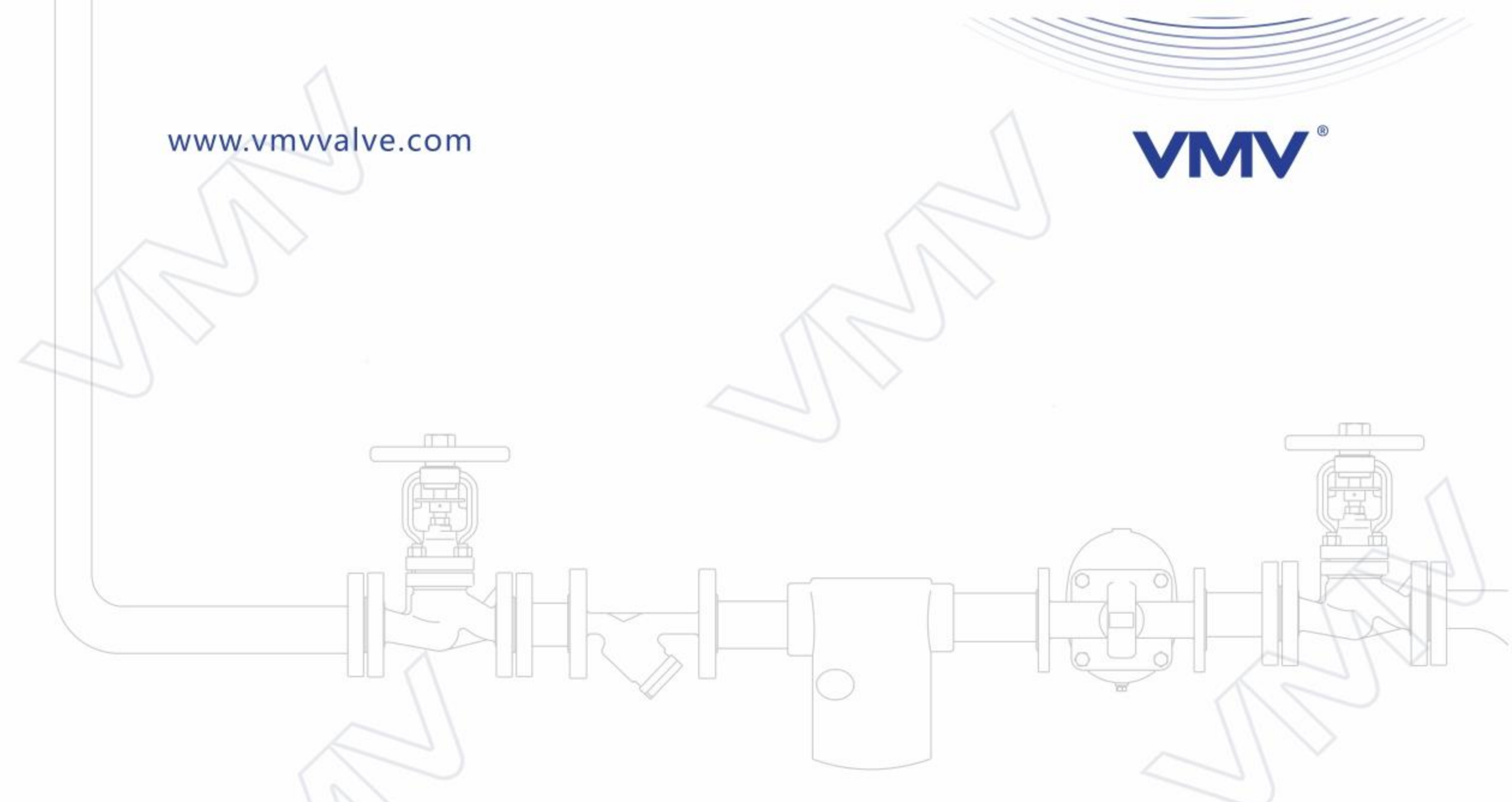

BELLOWS SEALED VALVES SERIES

- Bellows Sealed Globe Valve
- Bellows Sealed Gate Valve
- Lift Check Valve/ Y Strainer





VMV MISSION

- Committed to global energy saving and security
- Strive for the sustainable development of mankind



VMV VISION

- To become a respected brand providing steam and thermal energy system solutions to realize everyone's dream.



VMV VALUES

- Take responsibility
- Exert all one's energies
- Contribute to clients
- Walk the walk



VMV SPIRIT

- Integrity
- Altruism
- Innovation
- Efficiency



Shanghai R&D
(Brand Operation)Center



Since 1998

WWW.VMVVALVE.COM

350

Employees

75000m²

Factory Area

37

Engineers

2000m²

Laboratory Area

Committed To Global Energy Saving And Security
Strive For The Sustainable Development Of Mankind

致力于全球能源节约与安全
为人类可持续发展努力奋斗



VMV®



ABOUT VMV

VMV Newton is the professional valve manufacturer, integrating valve casting, complete machine research and development, production and sales. We established in 1998, the headquarter covers 75000 square meters and realizes digital intelligence integration workshop.

Our products have applied to steam system, thermal oil system, hot and cold water system, petroleum industry, natural gas industry, chemical industry etc.

We have also qualified with CE, ISO, TS A1, API, DNV, EAC certificates etc.



TRUE EFFICIENCY
USE VMV

HONORARY
CERTIFICATE



Workshop2
Bellows Sealed Valve Series



Workshop3
Steam Trap Series



Workshop5
General Valve &
Customized Valve Series



Workshop3
Control Valve Series

**PROFESSIONAL
MANUFACTURER OF VALVES**



**FORGED STEEL AUTOMATIC
PRODUCTION LINE**

This production line is operated by robots to turn, mill, drill, tap, and complete the whole processing at one time.



**INTELLIGENT THREE-
DIMENSIONAL WAREHOUSE**

Total 3000 storage spaces, with a height of 24 meters. It can accommodate 3,600 tons of materials, improving the utilization rate of the entire space and working efficiency.



INTELLIGENT CNC MACHINE

It can process large size valve up to 40", the processing accuracy up to UM level, to ensure that each valve has high precision, to ensure zero leakage.



VMV PRODUCTION MANAGEMENT

- Standardized production process
- High precision machining capability
- Accurate inventory data
- Strict quality control
- Protection of workers' health
- Environment and sustainable development



HIGH QUALITY CONTROL OF VMV



HIGH PRECISION GRINDING MACHINE

The grinding accuracy of the internal parts can be controlled within 3UM, and has excellent sealing performance.



FULL PROCESS INSPECTION

Complete process inspection from incoming inspection, process inspection and finished product inspection.



DUST-FREE WORKSHOP

Control dust, particles, bacteria and other pollutants in the production environment to ensure high-precision processing technology and high-clean product.



VMV TESTING LABORATORY

Equipped with spectrometer, Rockwell hardness tester, tensile testing machine, impact testing machine, metallographic testing machine, helium mass spectrometry microleak detector, etc.



HIGH PRECISION CONTROL OF VMV





The core theme of **VMV** is closely connected to Valve (Valve), doing our best (Max), helping customers succeed (Victory). Whenever and wherever special fluids need to be transported, controlled or shut down, the global customers rely on our expertise and products. **VMV** is committed to provide customers with the best advice, superior quality, highest reliability, as well as the reliable service.

Make security eternal. Welcome to **VMV**.

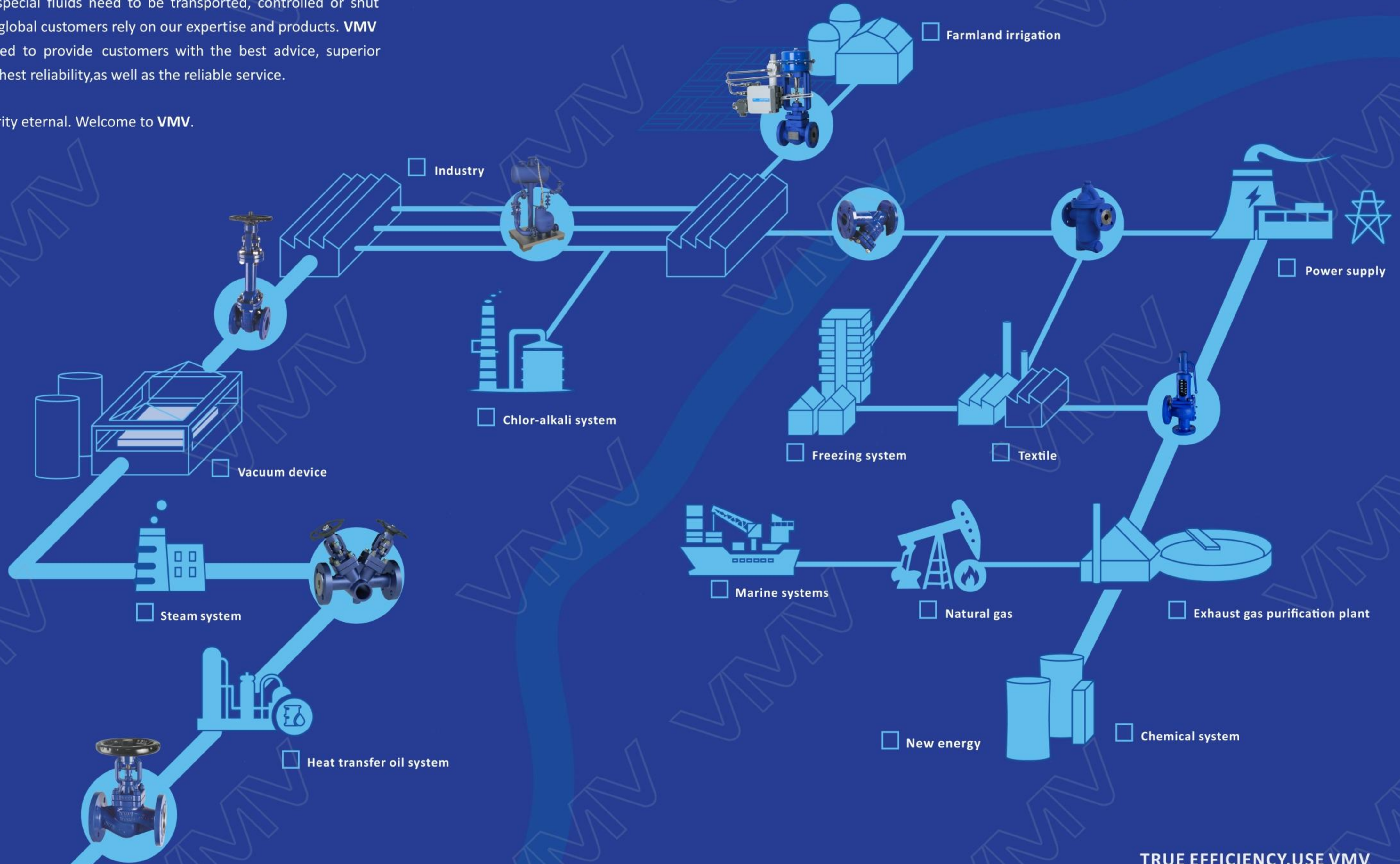

TRUE EFFICIENCY, USE VMV

Quality Control

- The test items of bellows sealed valves meet the requirements of different working conditions
- For the following general tests, VMV products have been tested in accordance with the specifications at the factory
- Users can make special tests and other tests according to the actual working conditions

Bellows Valve Check Items

General Detection		Inspection Items	Standard Specification
		Material Inspection	According To Relevant Material Standards
		Visual Inspection	MSS SP-55, JB/T 7927-2014
		Dimension Inspection	Machining Drawing File
		Pressure Test	API598, EN12266
		Air Tightness Test	API598, EN12266
		Valve Seat Leakage Check	API598, EN12266
		Functional Check	T/ZZB 1526-2020
		Bellows Leakage Check	T/ZZB 1526-2020
Special Detection		Test Items	Standard Specification
		RT Radiography	ASME
		PT Liquid Penetration Test	ASME
		UT Ultrasonic Inspection	ASME
		Low Leakage Detection	ISO15848

Common Subject Material Comparison Table

ASTM Casting	DIN/EN Casting	ASTM Forging	JIS Casting
A216 WCB	1.0619/GS-C25	ASTM A105	G5151 SCPH2
A536 60-40-80	JS1049/GGG40	-	G5502 FCD400-15
A352 LCB	1.1131/G17Mn5	A350 LF2	G5152 SCPL1
A217 WC6	1.7357/G17CrMo5-5	A182 F11	-
A217 WC9	1.7379/G17CrMo9-10	A182 F22	G5151 SCPH-32
A351 CF8	1.4308/GX5CrNi19-10	A182 F304	G5151 SCS13A
A351 CF3	1.4309/GX2CrNi19-11	A182 F304L	G5151 SCS19A
A351 CF8M	1.4408/GX5CrNiMo19-11-2	A182 F316	G5151 SCS14A
A351 CF3M	1.4409/GX2CrNiMo19-11-2	A182 F316L	G5151 SCS16A
A351 CF8C	1.4552/GX5CrNiNb19-11	A182 F316LN	G5151 SCC21
A351 CG8M	1.4412/GX5CrNiMo19-11-3	A182 F317	-

Bellow Material Comparison Table

GB	ASTM	DIN/EN
06Cr19Ni10	A240 304	1.4301
022Cr19Ni10	A240 304L	1.4306
06Cr17Ni12Mo2	A240 316	1.4401
022Cr17Ni12Mo2	A240 316L	1.4404
316Ti	A240 316Ti	1.4571
Gh625	Inconel 625	2.4856
Ni68Cu28Fe	Monel 400	2.4360
00Cr16Ni75Mo2Ti	Hastelloy C-276	2.4819

Advantages of VMV Bellows

Application

Bellows seal part is a safety device that maintains pressure sealing, it prevents the release of fluids or flammable gases into the atmosphere, realizing a safe and economical way to prevent medium leakage.

Material

VMV Standard bellows materials: SS304/SS316L.
Special bellows materials: Inconel 625/Hastelloy276/Monelalloy etc.

VMV can help customers choose suitable bellows for different working conditions.



Structure of Bellows

U-Type Bellows

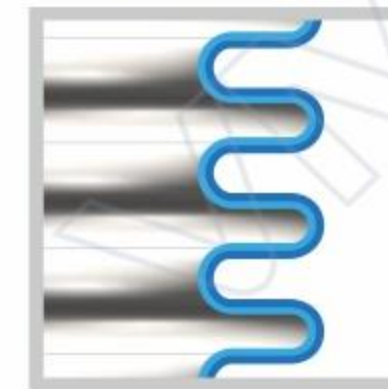

Ω-Type Bellows

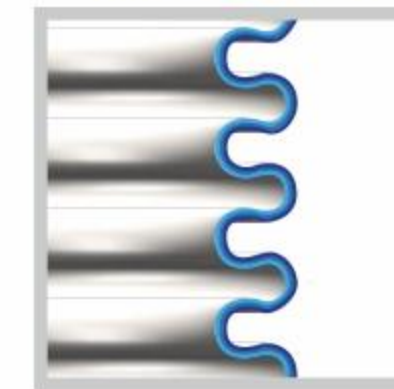

Standard bellows assembly



Extended bellows assembly

Metal bellows features

Pressure resistance, High temperature resistance, Corrosion resistance, Torque resistance, Fatigue resistant, Long life, High sensitivity.

Test of Bellows

100% Pressure test
100% Helium leak test
Meet ISO15848 Standard

Professional intelligent testing equipment from Europe to test the bellows.
100% performance test of bellows assembly before assembly.
Accuracy up to ΔP variables, Bellows leak rate less than 1X10⁻⁶ scc/sec.

Cycle life test of bellows

Test under pressure and high temperature

Globe valve ≥5000 times
Gate valve ≥2000 times

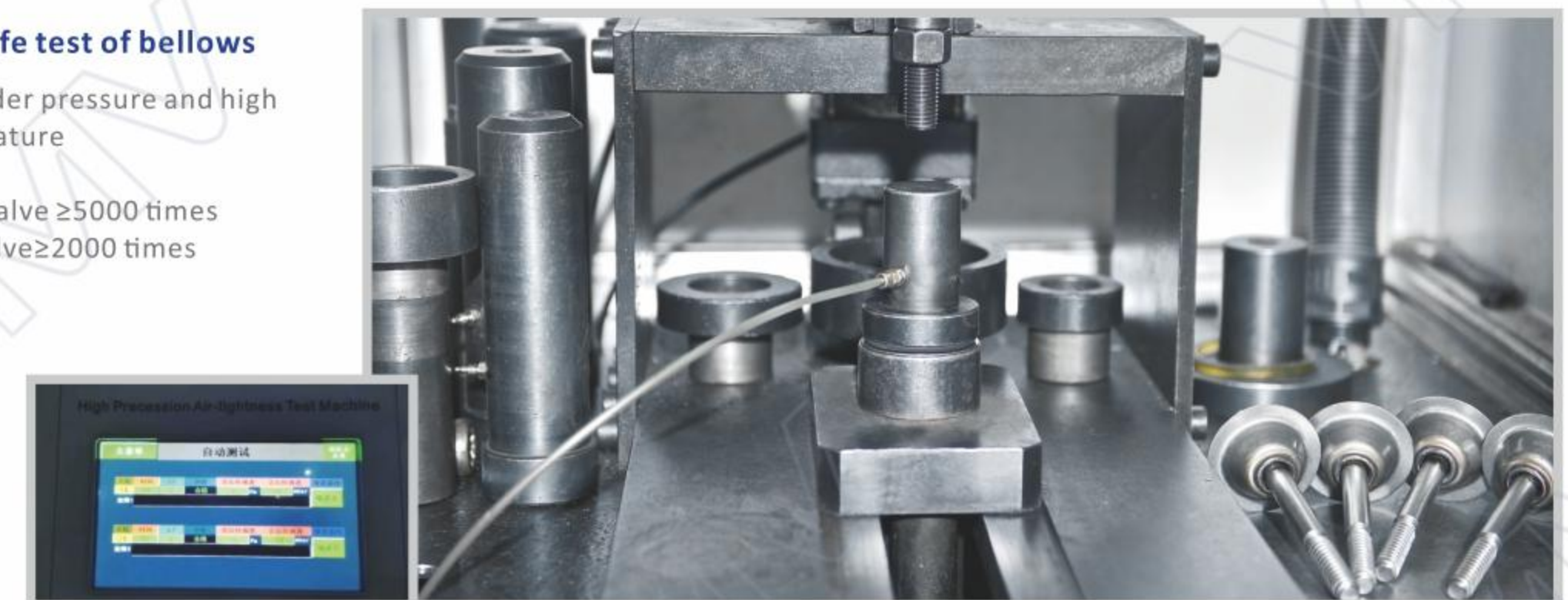

Product selection

Notes: ● Normal products ◇ Customized products ○ Forging technology

Name	Body	Model	PN	Size Conn	15-50	65-150	200	250	300	350	400	450	500	600
DIN STD BELLOWS SEALED GLOBE VALVE (PLUS)	GS-C25	WJ41H	PN10-PN25	RF	●	●	●	●	●	●	●	◇	●	◇
	CF8	WJ41H	PN40	RF	●	●	●	●	●	●	●	◇	●	◇
	CF8M	WJ61H	PN10-PN25	BW	○	●	●	●	●	●	●	◇	●	◇
		WJ61H	PN40	BW	○	●	●	●	●	●	●	◇	●	◇
BELLOWS SEALED GLOBE VALVE (EXTEND)	GS-C25	L-WJ41H	PN10-PN25	RF	●	●	●	●	●	●	●	◇	●	◇
	CF8	L-WJ41H	PN40	RF	●	●	●	●	●	●	●	◇	●	◇
	CF8M	L-WJ61H	PN10-PN25	BW	○	●	●	●	●	●	●	◇	●	◇
		L-WJ61H	PN40	BW	○	●	●	●	●	●	●	◇	●	◇
BELLOWS SEALED GLOBE VALVE (SUPER)	GS-C25	S-WJ41H	PN10-PN25	RF	●	●	●	●	◇	◇	◇	◇	◇	◇
	CF8	S-WJ41H	PN40	RF	●	●	●	●	◇	◇	◇	◇	◇	◇
	CF8M	S-WJ61H	PN10-PN25	BW	○	●	●	●	●	◇	◇	◇	◇	◇
		S-WJ61H	PN40	BW	○	●	●	●	●	◇	◇	◇	◇	◇
ANGLE TYPE BELLOWS SEALED GLOBE VALVE	GS-C25	WJ44H	PN10-PN25	RF	●	●	●	●	◇	◇	◇	◇	◇	◇
	CF8	WJ44H	PN40	RF	●	●	●	●	◇	◇	◇	◇	◇	◇
	CF8M	WJ64H	PN10-PN25	BW	○	●	●	●	●	◇	◇	◇	◇	◇
		WJ64H	PN40	BW	○	●	●	●	●	◇	◇	◇	◇	◇
Y TYPE BELLOWS SEALED GLOBE VALVE	GS-C25	WJ45H	PN10-PN25	RF	●	●	●	●	●	●	◇	◇	◇	◇
	CF8	WJ45H	PN40	RF	●	●	●	●	●	●	◇	◇	◇	◇
	CF8M	WJ65H	PN10-PN25	BW	○	●	●	●	●	●	◇	◇	◇	◇
		WJ65H	PN40	BW	○	●	●	●	●	●	◇	◇	◇	◇
JIS STD BELLOWS SEALED GLOBE VALVE	SCPH2	WJ41H	JIS 10K	RF	●	●	●	●	◇	◇	◇	◇	◇	◇
	CF8	WJ41H	JIS 20K	RF	●	●	●	●	◇	◇	◇	◇	◇	◇
	CF8M	WJ61H	JIS 10K	BW	○	●	●	●	●	◇	◇	◇	◇	◇
		WJ61H	JIS 20K	BW	○	●	●	●	●	◇	◇	◇	◇	◇
ANSI STD BELLOWS SEALED GLOBE VALVE	WCB	WJ41H	150Lb	RF	○	●	●	●	◇	◇	◇	◇	◇	◇
	CF8	WJ41H	300Lb	RF	○	●	●	●	◇	◇	◇	◇	◇	◇
		WJ41H	600Lb	RF	○	●	●	●	◇	◇	◇	◇	◇	◇
	CF8M	WJ61H	150Lb	BW	○	●	●	●	◇	◇	◇	◇	◇	◇
		WJ61H	300Lb	BW	○	●	●	●	◇	◇	◇	◇	◇	◇
	WJ61H	600Lb	BW	○	●	●	●	◇	◇	◇	◇	◇	◇	
FORGED STEEL BELLOWS SEALED GLOBE VALVE	A105	WJ41H	PN10-PN160	RF	●	●	●	●	◇	◇	◇	◇	◇	◇
	F304	WJ41H	150LB-900LB	RF	●	●	●	●	◇	◇	◇	◇	◇	◇
	F316	WJ61H	PN10-PN160	BW	●	●	●	●	◇	◇	◇	◇	◇	◇
		WJ61H	150LB-900LB	BW	●	●	●	●	◇	◇	◇	◇	◇	◇
LIFT CHECK VALVE	GS-C25	H41H	PN10-PN25	RF	●	●	●	●	●	◇	◇	◇	◇	◇
	CF8	H41H	PN40	RF	●	●	●	●	◇	◇	◇	◇	◇	◇
	CF8M	H61H	PN10-PN25	BW	○	●	●	●	●	◇	◇	◇	◇	◇
		H61H	PN40	BW	○	●	●	●	●	◇	◇	◇	◇	◇
Y STRAINER	GS-C25	H41H	PN10-PN25	RF	●	●	●	●	●	◇	◇	◇	◇	◇
	CF8	H41H	PN40	RF	●	●	●	●	●	◇	◇	◇	◇	◇
	CF8M	H61H	PN10-PN25	BW	○	●	●	●	●	◇	◇	◇	◇	◇
		H61H	PN40	BW	○	●	●	●	●	◇	◇	◇	◇	◇
DIN STD BELLOWS SEALED GATE VALVE	WCB	WZ41H	PN10-PN25	RF	●	●	●	●	●	●	◇	◇	●	◇
	CF8	WZ41H	PN40	RF	●	●	●	●	●	●	◇	◇	●	◇
	CF8M	WZ61H	PN10-PN25	BW	○	●	●	●	●	●	◇	◇	●	◇
		WZ61H	PN40	BW	○	●	●	●	●	●	◇	◇	●	◇
ANSI STD BELLOWS SEALED GATE VALVE	WCB	WZ41H	150Lb	RF	○	●	●	●	◇	◇	◇	◇	◇	◇
	CF8	WZ41H	300Lb	RF	○	●	●	●	◇	◇	◇	◇	◇	◇
		WZ41H	600Lb	RF	○	●	●	●	◇	◇	◇	◇	◇	◇
	CF8M	WZ61H	150Lb	BW	○	●	●	●	◇	◇	◇	◇	◇	◇
		WZ61H	300Lb	BW	○	●	●	●	◇	◇	◇	◇	◇	◇
	WZ61H	600Lb	BW	○	●	●	●	◇	◇	◇	◇	◇	◇	

Different materials and valve types are suitable for a variety of different working conditions. According to the performance of the medium, temperature, pressure, flow rate, and other characteristics combined with the process, operation, safety and other factors, users can select the corresponding valve specifications.



CONTENTS

- BELLOWS SEALED GLOBE VALVE 01-02
- DIN STANDARD BELLOWS SEALED GLOBE VALVE(PLUS) 03
- DIN STANDARD BELLOWS SEALED GLOBE VALVE(EXTEND) 04
- DIN STANDARD BELLOWS SEALED GLOBE VALVE(SUPER) 05
- DIN STANDARD BELLOW SEAL GLOBE CHECK VALVE 06
- ANSI STANDARD BELLOWS SEALED GLOBE VALVE 07
- ANSI STANDARD HIGH PRESSURE BELLOWS SEALED GLOBE VALVE 08
- JIS STANDARD BELLOWS SEALED GLOBE VALVE 09
- Y TYPE BELLOWS SEALED GLOBE VALVE 10
- ANGLE TYPE BELLOWS SEALED GLOBE VALVE 11
- DIN STANDARD GLAND PACKING GLOBE VALVE 12
- BELLOWS SEALED GATE VALVE 13-14
- DIN STANDARD BELLOW SEALED GATE VALVE 15
- ANSI STANDARD BELLOWS SEALED GATE VALVE 16
- FORGED STEEL BELLOWS SEALED VALVE 17-18
- FORGED STEEL BELLOWS SEALED GLOBE VALVE 19
- INTERGRAL FORGED STEEL BELLOWS SEALED GLOBE VALVE 20
- FORGED STEEL BELLOWS SEALED GLOBE VALVE (FOR HIGH TEMPERATURE AND HIGH PRESSURE) 21
- FORGED STEEL BELLOWS SEALED GATE VALVE 22
- LOW TEMPERATURE BELLOWS GATE VALVE 23
- BELLOWS SEALED MOLTEN SALT GLOBE VALVE 24
- DIN STANDARD LIFT CHECK VALVE 25-26
- DIN STANDARD Y STRAINER 27-28
- DIMENSIONS OF FLANGE CONNECTIONS 29-30
- CUSTOMIZED BELLOWS VALVE 31-32



BELLOWS SEALED GLOBE VALVE



Conical seal: The sealing surface has self-cleaning function and is not easy to adhere to impurities, which can achieve linear sealing.



Balanced disc seal: Small disc relieves pressure and drives large disc to open easily.



Flat soft seal: The surface of the soft seal can prevent the sparks when opening and closing, it's suitable for gas media and corrosion resistance conditions.



• Ergonomic hand wheel design



• Double seal design (bellows+packing)

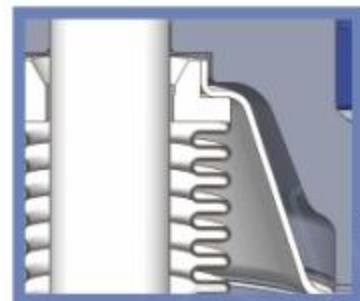

• Bellows transition connection
• Improve welding quality

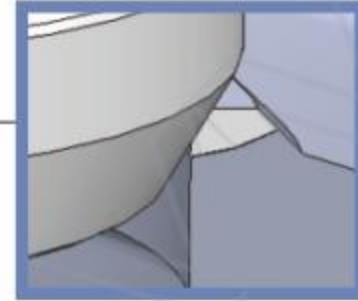

• Sealing surface overlay welding alloy layer
• Roughness $\leq 0.5\mu m$

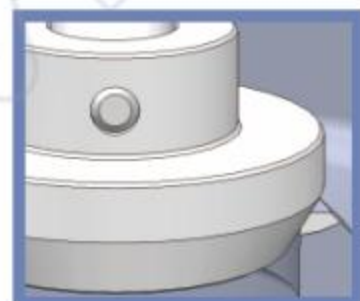

• Conical disc or other customized disc

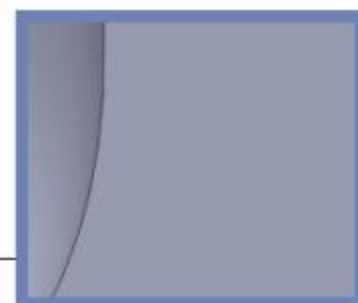
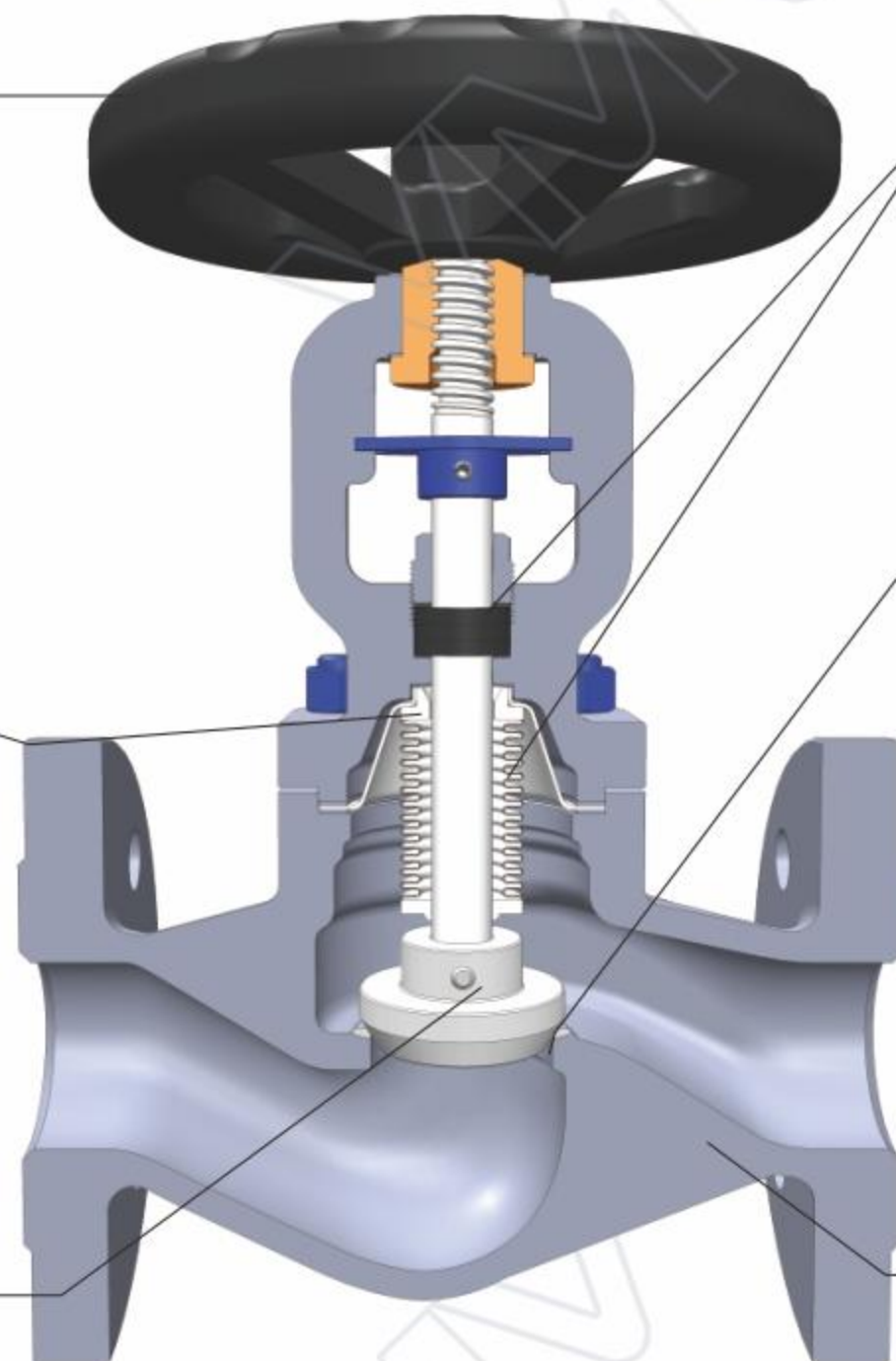

• German coated sand casting
• Surface finish: 12.5~25 microns

Application

Industry	Heating	Industrial Chemistry	Electricity	Pharmacy	Food	Tobacco	Printing	Air Conditioning	Shipbuilding
Medium	Steam	Thermal Oil	Ammonia Gas	Liquid Ammonia	Ethylene Glycol	Fatty Acid	Gases	Precious Fluids	Etc.....

Main Part Materials

Name	Material
Body	GS-C25、JS1049、CF8、CF8M、CF3M
Seat	13Cr、SS304、SS316、Stellite
Disc	13Cr、F304、F316、Stellite
Bellows	SS304、SS316L
Stem	20Cr13、F304、F316
Bonnet	GS-C25、JS1049、CF8、CF8M、CF3M

Performance Table

Nominal Pressure		PN(MPa)
Test Pressure	Shell Test	1.5 × Pr
	Sealing Test	1.1 × Pr
	Air Test	0.6
	Bellows Assembly Test	1.5 × Pr
Suitable Temp	-196°C~600°C	
Note: Pr is the pressure rating of the material at room temperature, the unit is MPa		

Selection and Application

According to the performance of the medium, temperature, pressure, flow rate, and other characteristics combined with the process, operation, safety and other factors, we can select the corresponding valve specifications.



DIN STANDARD BELLOWS SEALED GLOBE VALVE(PLUS)

DIN STANDARD BELLOWS SEALED GLOBE VALVE(EXTEND)

Product Advantage

- Conical disc design. Benefit from the cone and streamline shape design, the disc can remove the impurities, keep valve in reliable seal and longer service life.
- Double seal design (bellows+packing). Bellows design form a metal seal to prevent leakage, and packing can provide seal if the bellow failed.

- Patented central locate design. It can protect stem from tremble and lower noise, so the bellow has stable performance and long service life.
- Coated sand casting technology. Sand mixed with binder and other additives makes the rough casting with less defects like pore, trachoma and cracks, and better tensile strength.

Specifications

- Design standard: EN12516
- Face to face dimension: EN558
- Flange ends: EN1092-1
- Test & inspection: EN12266

Application

- Thermal oil, Steam, Hot and cold water, Fatty acids, Ammonia, Natural gas, etc.

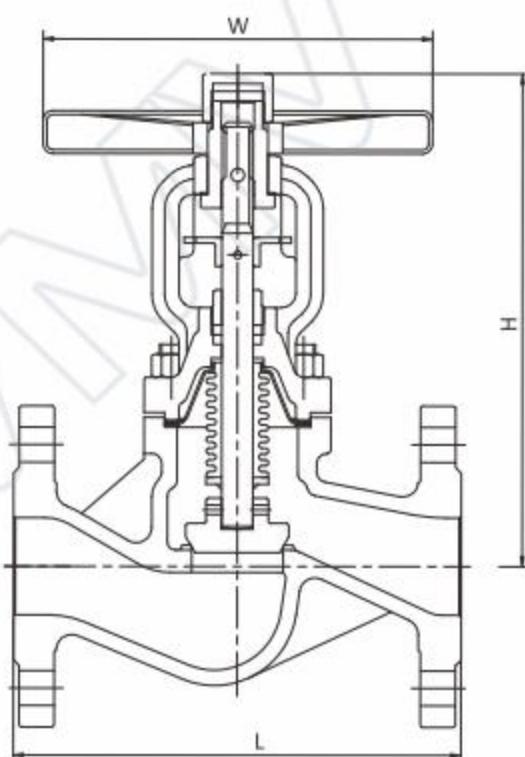

Data Dimension Table

DN	PN16			PN25			PN40		
	L	W	H≈	L	W	H≈	L	W	H≈
15	130	Φ140	192	130	Φ140	192	130	Φ140	192
20	150	Φ140	192	150	Φ140	192	150	Φ140	192
25	160	Φ160	207	160	Φ160	207	160	Φ160	207
32	180	Φ160	207	180	Φ160	207	180	Φ160	207
40	200	Φ180	234	200	Φ180	234	200	Φ180	234
50	230	Φ200	253	230	Φ200	253	230	Φ200	253
65	290	Φ220	305	290	Φ220	305	290	Φ220	305
80	310	Φ250	337	310	Φ250	337	310	Φ250	337
100	350	Φ300	391	350	Φ300	391	350	Φ300	391
125	400	Φ350	441	400	Φ350	441	400	Φ350	441
150	480	Φ400	497	480	Φ400	497	480	Φ400	497
200	600	Φ450	672	600	Φ450	672	600	Φ450	672
250	730	Φ550	775	730	Φ550	775	730	Φ550	775
300	850	Φ600	852	850	Φ600	852	850	Φ600	852
350	980	Φ700	1021	980	Φ700	1021	980	Φ700	1021
400	1100	Φ700	1140	1100	Φ700	1140	1100	Φ700	1140

Product Advantage

- Bellows protected space design. bellows are protected in a sealed space, not directly affected by the medium, pressure, temperature, achieving corrosion resistance and long life.

- The seal element of titanium is a reliable material for high temperature and corrosion condition, which will form a triple seal. It provides more reliable performance.

Specifications

- Design standard: EN12516
- Face to face dimension: EN558
- Flange ends: EN1092-1
- Test & inspection: EN12266

Application

- Thermal oil, Steam, Hot and cold water, Fatty acids, Ammonia, Natural gas, etc.

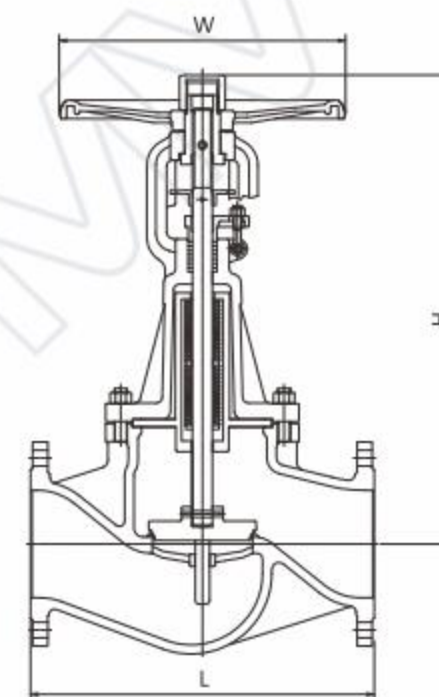

Data Dimension Table

DN	PN16			PN25			PN40		
	L	W	H≈	L	W	H≈	L	W	H≈
15	130	Φ140	228	130	Φ140	228	130	Φ140	228
20	150	Φ140	228	150	Φ140	228	150	Φ140	228
25	160	Φ160	248	160	Φ160	248	160	Φ160	248
32	180	Φ160	248	180	Φ160	248	180	Φ160	248
40	200	Φ180	295	200	Φ180	295	200	Φ180	295
50	230	Φ200	340	230	Φ200	340	230	Φ200	340
65	290	Φ220	378	290	Φ220	378	290	Φ220	378
80	310	Φ250	408	310	Φ250	408	310	Φ250	408
100	350	Φ300	500	350	Φ300	500	350	Φ300	500
125	400	Φ350	580	400	Φ350	580	400	Φ350	580
150	480	Φ400	658	480	Φ400	658	480	Φ400	658
200	600	Φ450	845	600	Φ450	845	600	Φ450	845
250	730	Φ500	970	730	Φ500	970	730	Φ500	970
300	850	Φ600	1080	850	Φ600	1080	850	Φ600	1080
350	980	Φ600	1220	980	Φ600	1220	980	Φ600	1220
400	1100	Φ700	1390	1100	Φ700	1390	1100	Φ700	1390

DIN STANDARD BELLOWS SEALED GLOBE VALVE(SUPER)

DIN STANDARD BELLOW SEAL GLOBE CHECK VALVE

Product Advantage

- Double stem. It's combined with upper-stem and lower-stem, with wear-resisting material and anti-corrosion material, meet the requirement of wear and corrosion resistance.
- Bellows protected space design. Bellows are protected in a sealed space, not directly affected by the medium, pressure, temperature, achieving corrosion resistance and long life.

- Back sealed design, with travel limit and bellows anti-vibration device in the open position, ensuring that the valve can work under harsh conditions.

Specifications

- Design standard: EN12516
- Face to face dimension: EN558
- Flange ends: EN1092-1
- Test & inspection: EN12266

Application

Dry chlorine or liquid chlorine, Petroleum, Chemical Industry, Pharmacy, Fertilizer, Power Industry Etc.

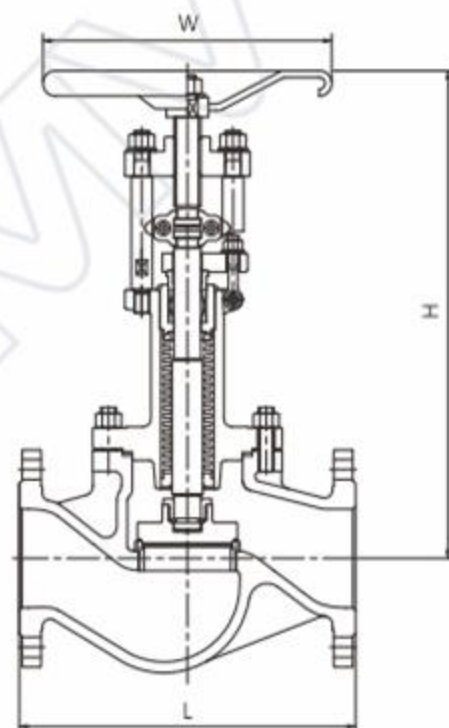

Data Dimension Table

DN	PN16			PN25			PN40		
	L	W	H≈	L	W	H≈	L	W	H≈
15	130	Φ140	250	130	Φ140	250	130	Φ140	250
20	150	Φ140	250	150	Φ140	250	150	Φ140	250
25	160	Φ160	259	160	Φ160	259	160	Φ160	259
32	180	Φ160	259	180	Φ160	259	180	Φ160	259
40	200	Φ180	385	200	Φ180	385	200	Φ180	385
50	230	Φ200	389	230	Φ200	389	230	Φ200	389
65	290	Φ220	404	290	Φ220	404	290	Φ220	404
80	310	Φ250	476	310	Φ250	476	310	Φ250	476
100	350	Φ300	495	350	Φ300	495	350	Φ300	495
125	400	Φ350	667	400	Φ350	667	400	Φ350	667
150	480	Φ350	680	480	Φ350	680	480	Φ350	680
200	600	Φ450	829	600	Φ450	829	600	Φ450	829
250	730	Φ550	964	730	Φ550	964	730	Φ550	964
300	850	Φ600	1039	850	Φ600	1039	850	Φ600	1039
350	980	Φ700	1340	980	Φ700	1340	980	Φ700	1340
400	1100	Φ700	1500	1100	Φ700	1500	1100	Φ700	1500

Product Advantage

- German coated sand casting technology. casting surface smoothness reaches 12.5-25 microns. Good mechanical performance, with over 98% free from defects.
- Conical disc design. Benefit from the cone and streamline shape design, the disc can remove the impurity, keep valve in reliable seal and longer service life.

- Treated by quenching and tempering and surface nitriding, the stems have good performance of anti-corrosion and anti-friction.
- Various valve disc designs can be provided according to different working conditions, such as throttle valve disc, regulating valve disc, flat soft sealing valve disc, globe check valve disc, etc.

Specifications

- Design standard: EN12516
- Face to face dimension: EN558
- Flange ends: EN1092-1
- Test & inspection: EN12266

Application

Thermal oil, Steam, Hot and cold water, Fatty acids, Ammonia, Natural gas, etc.

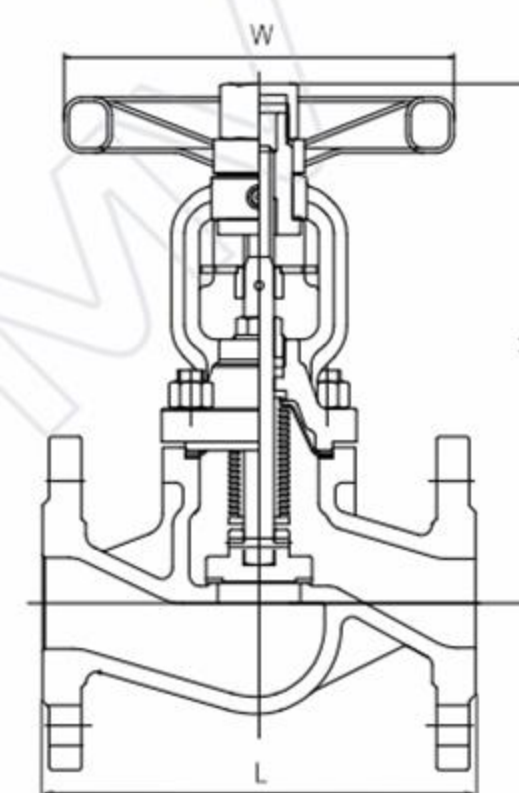

Data Dimension Table

DN	PN16			PN25			PN40		
	L	W	H≈	L	W	H≈	L	W	H≈
15	130	Φ140	192	130	Φ140	192	130	Φ140	192
20	150	Φ140	192	150	Φ140	192	150	Φ140	192
25	160	Φ160	207	160	Φ160	207	160	Φ160	207
32	180	Φ160	207	180	Φ160	207	180	Φ160	207
40	200	Φ180	234	200	Φ180	234	200	Φ180	234
50	230	Φ200	253	230	Φ200	253	230	Φ200	253
65	290	Φ220	305	290	Φ220	305	290	Φ220	305
80	310	Φ250	337	310	Φ250	337	310	Φ250	337
100	350	Φ300	391	350	Φ300	391	350	Φ300	391
125	400	Φ350	441	400	Φ350	441	400	Φ350	441
150	480	Φ400	497	480	Φ400	497	480	Φ400	497
200	600	Φ450	672	600	Φ450	672	600	Φ450	672
250	730	Φ550	775	730	Φ550	775	730	Φ550	775
300	850	Φ600	852	850	Φ600	852	850	Φ600	852
350	980	Φ700	1021	980	Φ700	1021	980	Φ700	1021
400	1100	Φ700	1140	1100	Φ700	1140	1100	Φ700	1140

ANSI STANDARD BELLOWS SEALED GLOBE VALVE

ANSI STANDARD HIGH PRESSURE BELLOWS SEALED GLOBE VALVE

Product Advantage

- Bellows sealed element. The key part metal bellows is the connection between bonnet and stem by automatic roll welding. It can keep the stem part zero leakage.
- Benefited from the cone and streamline shape design, the disc has reliable sealing performance and longer service life.

- Double seal design (bellows + packing). Bellows and packing can prevent from leakage and provide excellent sealing performance.
- Grease nipple. It can directly lubricate the stem, nut and sleeve.
- Ergonomic hand wheel. It provides longer service life and easier operation.

Specifications

- Design standard: ASME B16.34
- Face to face dimension: ASME B16.10
- Flange ends: ASME B16.5
- Test & inspection: API598

Application

Thermal oil, Steam, Hot and cold water, Fatty acids, Ammonia, Natural gas, etc.

Product Advantage

- The key parts of the metal bellows, the lower end and the valve stem assembly are automatically welded, and the upper end and the connecting plate are automatically welded, it form a metal barrier between the fluid medium and the atmosphere to ensure zero leakage of the valve stem.

- The metal bellows are not directly affected by the medium under the action of the protective sleeve. When valve fully opened, the valve disc is in contact with the protective sleeve so that the bellows are sealed in the protective sleeve and are not affected by pressure and temperature, and the service life is longer.

Specifications

- Design standard: ASME B16.34
- Face to face dimension: ASME B16.10
- Flange ends: ASME B16.5
- Test & inspection: API598

Application

Thermal oil, Steam, Hot and cold water, Fatty acids, Ammonia, Natural gas, etc.

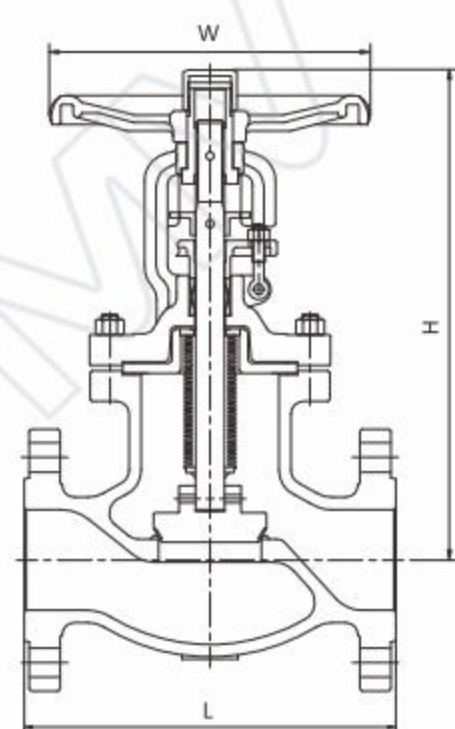

Data Dimension Table

Material	NPS	150LB			300LB		
		L	W	H≈	L	W	H≈
A105	1/2"	108	Φ120	240	152	Φ140	240
	3/4"	117	Φ120	240	178	Φ140	240
	1"	127	Φ140	256	203	Φ160	256
	1 1/4"	140	Φ140	267	216	Φ160	267
	1 1/2"	165	Φ160	325	229	Φ180	325
	2"	203	Φ200	348	267	Φ200	348
WCB	2"	203	Φ200	315	267	Φ220	328
	2 1/2"	216	Φ220	330	292	Φ250	355
	3"	241	Φ240	380	318	Φ300	414
	4"	292	Φ300	405	356	Φ350	433
	5"	356	Φ350	455	400	Φ400	452
	6"	406	Φ400	513	444	Φ450	545
	8"	495	Φ450	683	559	Φ600	725
	10"	622	Φ550	736	622	Φ600	798
	12"	698	Φ600	820	711	Φ600	933
	14"	787	-	-	838	-	-
16"	914	-	-	864	-	-	

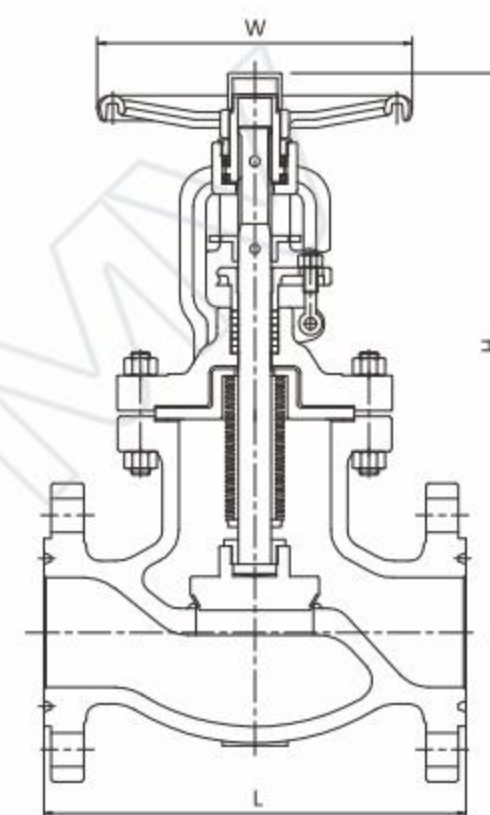

Data Dimension Table

Material	NPS	150LB			300LB		
		L	W	H≈	L	W	H≈
A105	1/2"	165	Φ140	240	165	Φ140	240
	3/4"	190	Φ140	240	190	Φ140	240
	1"	216	Φ160	256	216	Φ160	256
	1 1/2"	241	Φ160	267	241	Φ160	267
	2"	295	Φ200	348	295	Φ200	348
WCB	2"	295	Φ250	395	295	Φ300	395
	2 1/2"	333	Φ300	448	333	Φ350	448
	3"	359	Φ350	503	359	Φ350	503
	4"	435	Φ350	579	435	Φ350	595
	6"	562	Φ450	760	562	Φ500	790
	8"	663	Φ550	995	663	Φ600	1015

JIS STANDARD BELLOWS SEALED GLOBE VALVE

Y TYPE BELLOWS SEALED GLOBE VALVE

Product Advantage

- Conical disc design. Benefit from the cone and streamline shape design, the disc can remove the impurities, keep valve in reliable seal and longer service life.
- Double seal design (bellows+packing). Bellows design form a metal seal to prevent leakage, and packing can provide seal if the bellow failed.

- Patented central locate design. It can protect stem from tremble and lower noise, so the bellow is with stable performance and long service life.
- German coated sand casting technology. Sand mixed with binder and other additives, which makes the rough casting with less defects like pore, trachoma and cracks, and better tensile strength.

Specifications

- Design standard: JIS B2071
- Face to face dimension: JIS B2002
- Flange ends: JIS B2220
- Test & Inspection: JIS B2003

Application

Thermal oil, Steam, Hot and cold water, Fatty acids, Ammonia, Natural gas, etc.

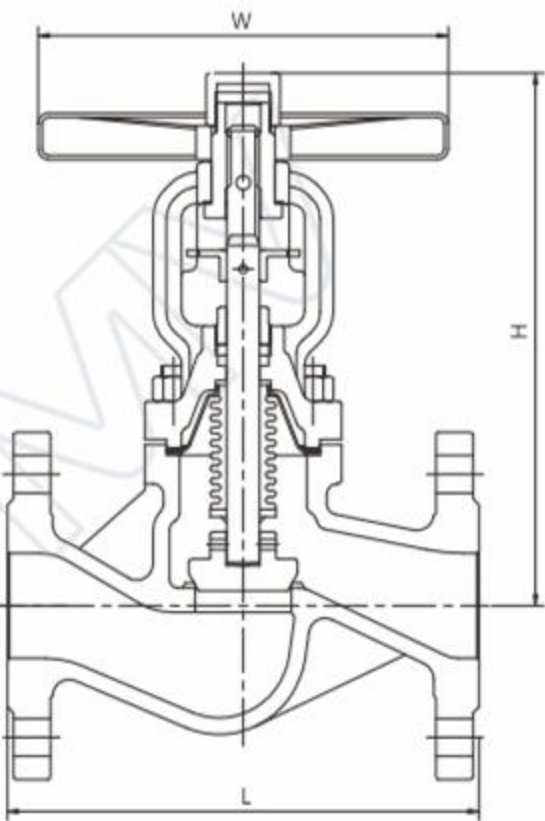

Data Dimension Table

DN	10K			20K		
	L	W	H≈	L	W	H≈
15	130	Ø140	192	130	Ø140	192
20	150	Ø140	192	150	Ø140	192
25	160	Ø160	207	160	Ø160	207
32	180	Ø160	207	180	Ø160	207
40	200	Ø180	234	200	Ø180	234
50	230	Ø200	253	230	Ø200	253
65	290	Ø220	305	290	Ø220	305
80	310	Ø250	337	310	Ø250	337
100	350	Ø300	391	350	Ø300	391
125	400	Ø350	441	400	Ø350	441
150	480	Ø400	497	480	Ø400	497
200	600	Ø450	672	600	Ø450	672
250	730	Ø550	775	730	Ø550	775
300	850	Ø600	852	850	Ø600	852
350	980	Ø700	1021	980	Ø700	1021
400	1100	Ø700	1140	1100	Ø700	1140

Product Advantage

- Straight flow structure. The fluid resistance of the structure is small, it can accelerate the flow rate of the medium, reduce the pressure loss and energy loss, especially for the medium with viscosity and easy to caking.

- Double seal design (bellows+packing). Bellows and packing can protect from leakage and provide excellent sealing performance
- Conical disc design. Benefit from the cone and streamline shape design, the disc can remove the impurities, keep valve in reliable seal and longer service life.

Specifications

- Design standard: EN12516
- Face to face dimension: EN558
- Flange ends: EN1092-1
- Test & inspection: EN12266

Application

Thermal oil, Steam, Hot and cold water, Fatty acids, Ammonia, Natural gas, etc.

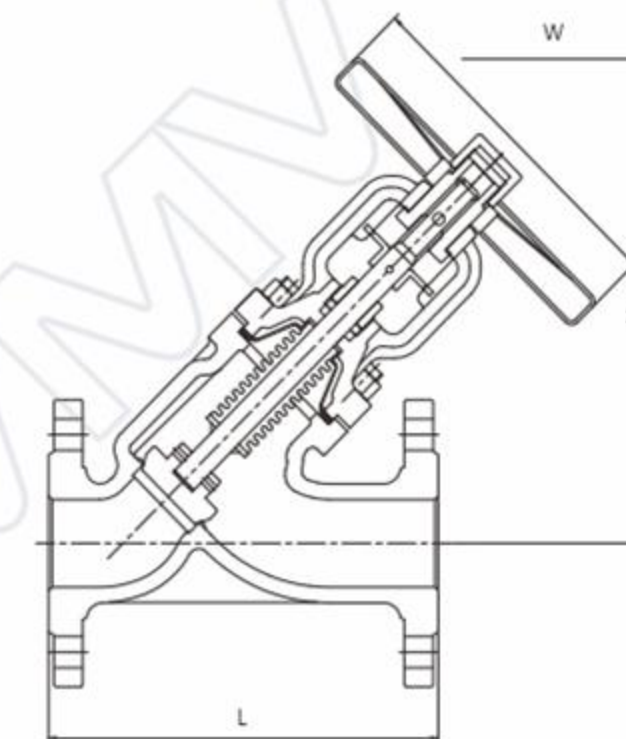

Data Dimension Table

DN	PN16			PN25			PN40		
	L	W	H≈	L	W	H≈	L	W	H≈
15	130	Ø140	191	130	Ø140	191	130	Ø140	191
20	150	Ø140	196	150	Ø140	196	150	Ø140	196
25	160	Ø160	216	160	Ø160	216	160	Ø160	216
32	180	Ø160	226	180	Ø160	226	180	Ø160	226
40	200	Ø180	254	200	Ø180	254	200	Ø180	254
50	230	Ø200	280	230	Ø200	280	230	Ø200	280
65	290	Ø220	320	290	Ø220	320	290	Ø220	320
80	310	Ø250	362	310	Ø250	362	310	Ø250	362
100	350	Ø300	437	350	Ø300	437	350	Ø300	437
125	400	Ø350	480	400	Ø350	480	400	Ø350	480
150	480	Ø400	575	480	Ø400	575	480	Ø400	575
200	600	Ø450	731	600	Ø450	731	600	Ø450	731
250	730	Ø550	900	730	Ø550	900	730	Ø550	900
300	850	Ø600	950	850	Ø600	950	850	Ø600	950
350	980	Ø700	1125	980	Ø700	1125	980	Ø700	1125
400	1100	Ø700	1235	1100	Ø700	1235	1100	Ø700	1235

ANGLE TYPE BELLOWS SEALED GLOBE VALVE

DIN STANDARD GLAND PACKING GLOBE VALVE

Product Advantage

- The outlet is 90° right Angle, suitable for installation at the corner of the pipeline system, which can save 90° elbow and save space, easy to operate.
- Double seal design(bellows+packing). Bellows and packing can protect from leakage and provide excellent sealing performance.

Specifications

- Design standard: EN12516
- Face to face dimension: EN558
- Flange ends: EN1092-1
- Test & inspection: EN12266

Application

Thermal oil, Steam, Hot and cold water, Fatty acids, Ammonia, Natural gas, etc.

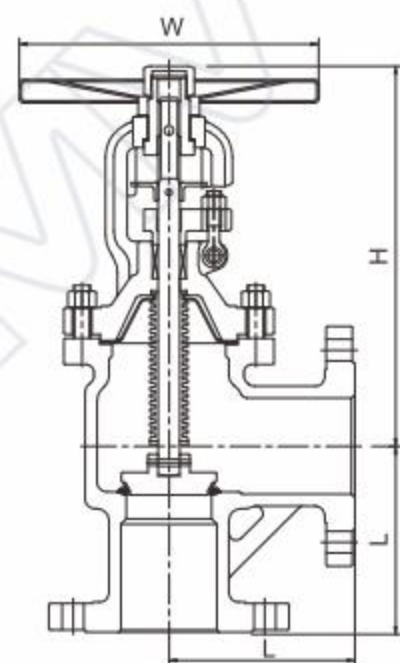

Data Dimension Table

DN	PN16			PN25			PN40		
	L	W	H≈	L	W	H≈	L	W	H≈
15	90	Φ140	177	90	Φ140	177	90	Φ140	177
20	95	Φ140	177	95	Φ140	177	95	Φ140	177
25	100	Φ160	189	100	Φ160	189	100	Φ160	189
32	105	Φ160	189	105	Φ160	189	105	Φ160	189
40	115	Φ180	219	115	Φ180	219	115	Φ180	219
50	125	Φ200	238	125	Φ200	238	125	Φ200	238
65	145	Φ220	287	145	Φ220	287	145	Φ220	287
80	155	Φ250	320	155	Φ250	320	155	Φ250	320
100	175	Φ300	384	175	Φ300	384	175	Φ300	384
125	200	Φ350	407	200	Φ350	407	200	Φ350	407
150	225	Φ400	470	225	Φ400	470	225	Φ400	470
200	275	Φ450	630	275	Φ450	630	275	Φ450	630
250	325	Φ550	692	325	Φ550	692	325	Φ550	692
300	375	Φ600	840	375	Φ600	840	375	Φ600	840
350	425	Φ700	990	425	Φ700	990	425	Φ700	990
400	475	Φ700	1100	475	Φ700	1100	475	Φ700	1100

Product Advantage

- German coated sand casting technology, casting surface smoothness reaches 12.5-25microns.
- Conical disc design. Benefit from the cone and streamline shape design, the disc can remove the impurity, keep valve in reliable seal and longer service life.

Specifications

- Treated by quenching and tempering and surface nitriding, the stems have good performance of anti-corrosion and anti-friction.

- Various valve disc designs can be provided according to working conditions, such as throttle valve disc, regulating valve disc, flat soft sealing valve disc, globe check valve disc, etc.

Specifications

- Design standard: EN12516
- Face to face dimension: EN558
- Flange ends: EN1092-1
- Test & inspection: EN12266

Application

Thermal oil, Steam, Hot and cold water, Chemical industry etc.

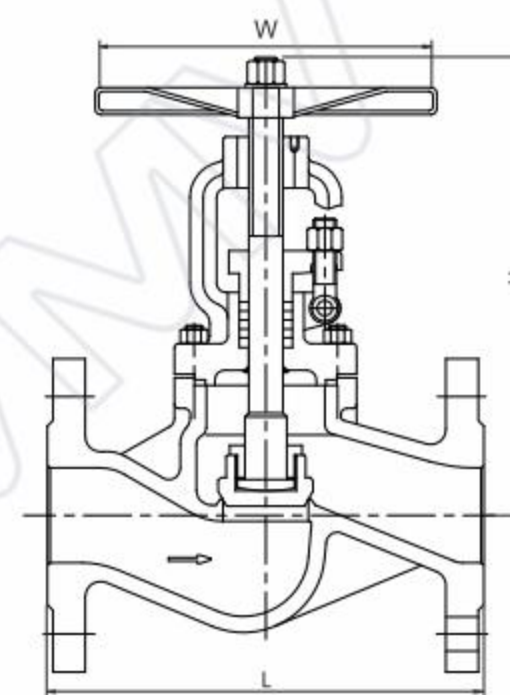

Data Dimension Table

DN	PN16			PN25			PN40		
	L	W	H≈	L	W	H≈	L	W	H≈
15	130	Φ140	195	130	Φ140	195	130	Φ140	195
20	150	Φ140	195	150	Φ140	195	150	Φ140	195
25	160	Φ160	211	160	Φ160	211	160	Φ160	211
32	180	Φ160	211	180	Φ160	211	180	Φ160	211
40	200	Φ180	252	200	Φ180	252	200	Φ180	252
50	230	Φ200	254	230	Φ200	254	230	Φ200	254
65	290	Φ220	287	290	Φ220	287	290	Φ220	287
80	310	Φ250	310	310	Φ250	310	310	Φ250	310
100	350	Φ300	365	350	Φ300	365	350	Φ300	365
125	400	Φ350	433	400	Φ350	433	400	Φ350	433
150	480	Φ400	465	480	Φ400	465	480	Φ400	465
200	600	Φ450	550	600	Φ450	550	600	Φ450	550
250	730	Φ550	775	730	Φ550	775	730	Φ550	775
300	850	Φ600	850	850	Φ600	850	850	Φ600	850
350	980	Φ700	1005	980	Φ700	1005	980	Φ700	1005
400	1100	Φ700	1140	1100	Φ700	1140	1100	Φ700	1140

BELLOWS SEALED GATE VALVE

The key part metal bellows, with the lower end welded to the valve stem and the upper end welded to the connecting plate. Form a metal barrier between the medium and the atmosphere to ensure zero leakage of the valve stem.

Fugitive emission test of bellows: 100% pass according to ISO15848-A



Welding of bellows assembly: microcomputer controlled welding speed to ensure the quality of the key part.

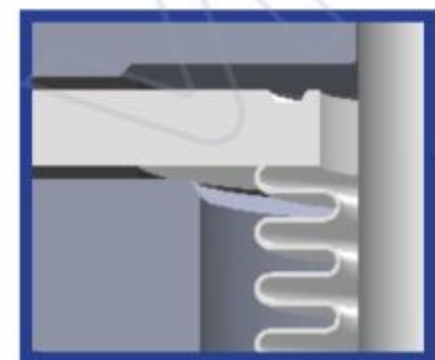
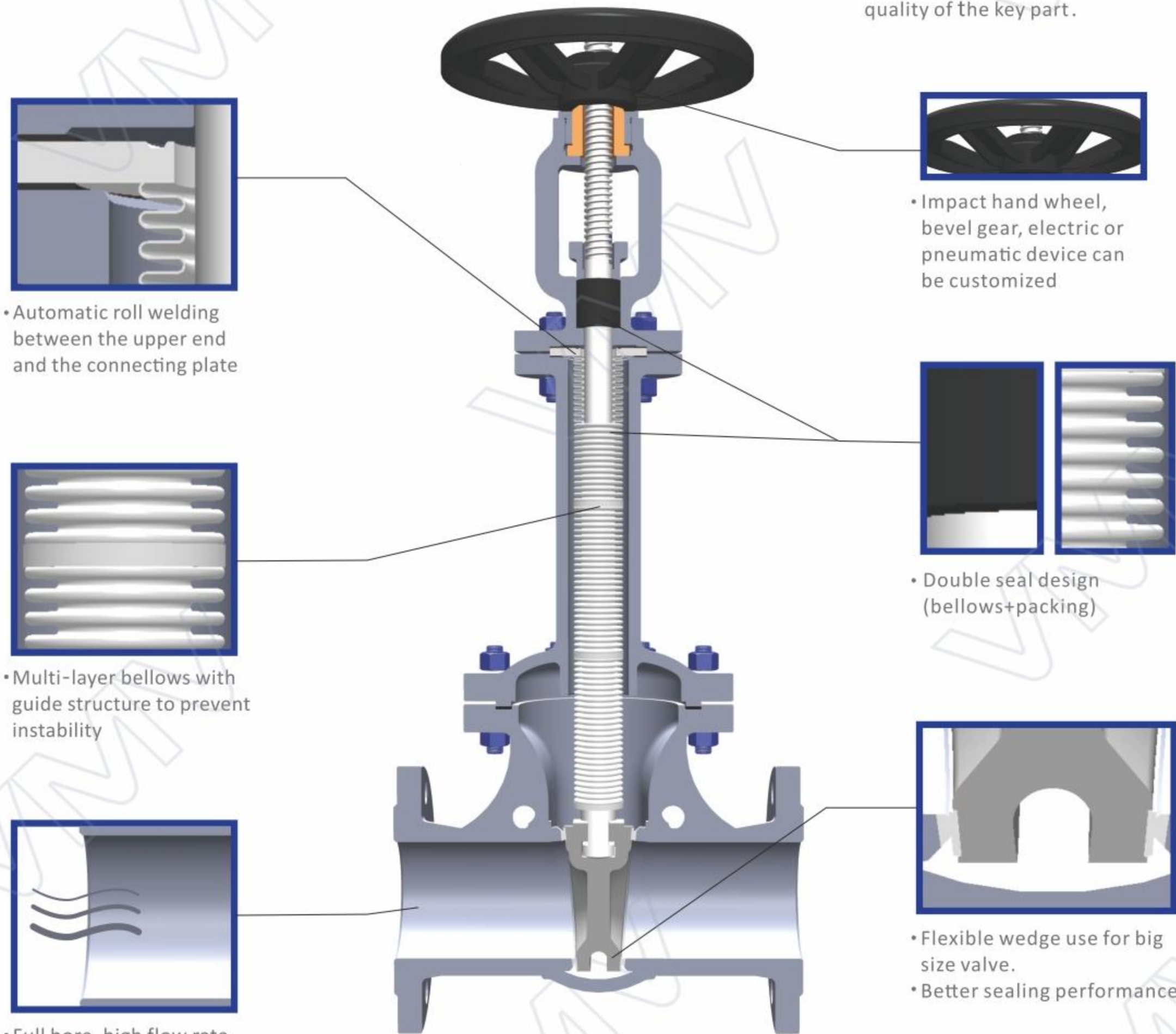

• Automatic roll welding between the upper end and the connecting plate

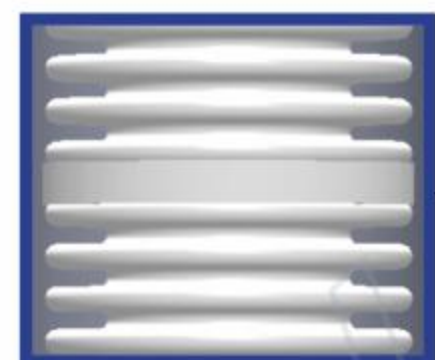

• Multi-layer bellows with guide structure to prevent instability



• Full bore, high flow rate, zero flow resistance



• Impact hand wheel, bevel gear, electric or pneumatic device can be customized



• Double seal design (bellows+packing)



• Flexible wedge use for big size valve.
• Better sealing performance

Application

Industry	Heating	Industrial Chemistry	Electricity	Pharmacy	Food	Tobacco	Printing	Air Conditioning	Shipbuilding
Medium	Steam	Thermal Oil	Ammonia Gas	Liquid Ammonia	Ethylene Glycol	Fatty Acid	Gases	Precious Fluids	Etc....

Main Part Materials

Name	Material
Body	WCB, WC6, CF8, CF8M
Seat	13Cr, Stellite
Disc	WCB+13Cr, Stellite
Bellows	SS304, SS316L
Stem	20Cr13, F304, F316
Bonnet	WCB, WC6, CF8, CF8M

Performance Table

Nominal Pressure		PN(MPa)
Test Pressure	Shell Test	1.5 × Pr
	Sealing Test	1.1 × Pr
	Air Test	0.6
	Bellows Assembly Test	1.5 × Pr

Suitable Temp	-196°C~600°C
---------------	--------------

Note: Pr is the pressure rating of the material at room temperature, the unit is MPa

Selection and Application

According to the performance of the medium, temperature, pressure, flow rate, and other characteristics combined with the process, operation, safety and other factors, select the corresponding valve specifications.



DIN STANDARD BELLOW SEALED GATE VALVE

ANSI STANDARD BELLOWS SEALED GATE VALVE

Product Advantage

- The key parts of the metal bellows, the lower end and the valve stem assembly are automatically welded, and the upper end and the connecting plate are automatically welded, it form a metal barrier between the fluid medium and the atmosphere to ensure zero leakage of the valve stem.
- Double sealing design with bellows and packing, with dual safety, makes the sealing at the valve stem safer and more reliable.

- Grease nipple. It can directly lubricate the stem, nut and sleeve.
- Ergonomic hand wheel. It provides longer service life and easier operation.

Specifications

- Design standard: EN12516
- Face to face dimension: EN558
- Flange ends: EN1092-1
- Test & inspection: EN12266

Application

Thermal oil, Steam, Hot and cold water, Fatty acids, Ammonia, Natural gas, etc.

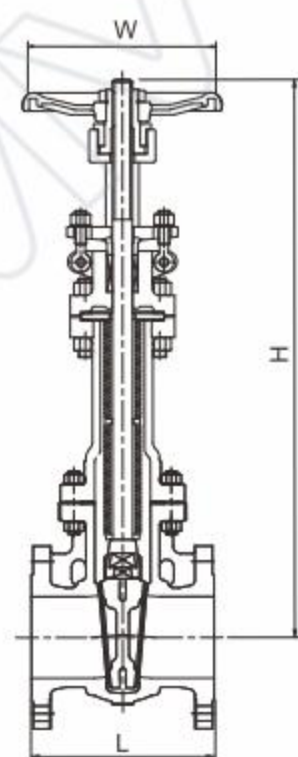

Data Dimension Table

DN	PN16			PN25			PN40		
	L	W	H≈	L	W	H≈	L	W	H≈
50	250	Φ220	500	250	Φ220	500	250	Φ220	500
65	265	Φ240	560	265	Φ240	560	280	Φ240	560
80	280	Φ280	620	280	Φ280	620	310	Φ280	620
100	300	Φ300	800	300	Φ300	800	350	Φ300	800
125	325	Φ320	900	325	Φ320	900	400	Φ320	900
150	350	Φ350	1105	350	Φ350	1105	450	Φ350	1105
200	400	Φ400	1385	400	Φ400	1385	550	Φ400	1385
250	450	Φ450	1600	450	Φ450	1600	650	Φ450	1600
300	500	Φ500	1950	500	Φ500	1950	750	Φ500	1950
350	550	Φ550	2250	550	Φ550	2250	850	Φ550	2250
400	600	Φ600	2550	600	Φ600	2550	950	Φ600	2550
450	650	Φ650	2760	650	Φ650	2760	1050	Φ650	2760
500	700	Φ700	3150	700	Φ700	3150	1150	Φ700	3150
600	800	Φ750	3900	800	Φ750	3900	1350	Φ750	3900

Product Advantage

- The key parts of the metal bellows, the lower end and the valve stem assembly are automatically welded, and the upper end and the connecting plate are automatically welded, which form a metal barrier between the fluid medium and the atmosphere to ensure zero leakage of the valve stem.
- Double sealing design with bellows and packing, with dual safety, makes the sealing of the valve stem safer and more reliable.

- Grease nipple. It can directly lubricate the stem, nut and sleeve.
- Ergonomic hand wheel. It provides longer service life and easier operation.

Specifications

- Design standard: ASME B16.34/API600
- Face to face dimension: ASME B16.10
- Flange ends: ASME B16.5
- Test & inspection: API598

Application

Thermal oil, Steam, Hot and cold water, Fatty acids, Ammonia, Natural gas, etc.

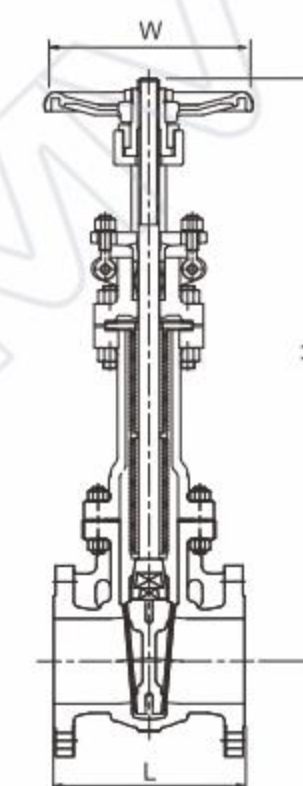

Data Dimension Table

Material	NPS	150Lb			300Lb		
		L	W	H≈	L	W	H≈
A105	1/2 "	108	Φ95	210	140	Φ95	210
	3/4 "	117	Φ95	215	152	Φ95	215
	1	127	Φ117	245	165	Φ117	245
	1 1/4	140	Φ145	280	178	Φ145	280
	1 1/2	165	Φ145	295	190	Φ145	295
	2 "	178	Φ170	363	216	Φ170	363
WCB	2 "	178	Φ220	415	216	Φ220	415
	2 1/2	190	Φ240	560	241	Φ240	560
	3 "	203	Φ280	620	283	Φ280	620
	4 "	229	Φ300	670	305	Φ300	670
	5 "	254	Φ320	810	381	Φ320	810
	6 "	267	Φ350	900	403	Φ350	900
	8 "	292	Φ400	1100	419	Φ400	1100
	10 "	330	Φ450	1480	457	Φ450	1480
	12 "	356	Φ500	1890	502	Φ500	1890
	14 "	381	Φ550	2250	762	Φ550	2250
	16 "	406	Φ600	2550	838	Φ600	2550
	18 "	432	Φ700	2760	914	-	-
	20 "	457	Φ700	3150	991	-	-

FORGED STEEL BELLOWS SEALED VALVE

Compared with castings, the forged steel body has a more stable structure, better density, better strength and smaller dimensional error.

Better performance of strength and stress. Longer service life even in places where stress and crystal corrosion are severe.

Hot forging process, especially suitable for high temperature, high pressure, toxic, high permeability and other harsh conditions.



- Split packing gland
- Automatic aligning function

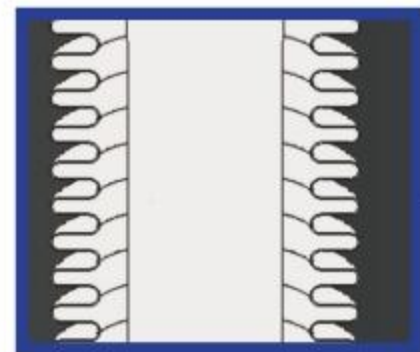

- The length of the bellows is 5 times the stroke of the valve opening
- Increase service life

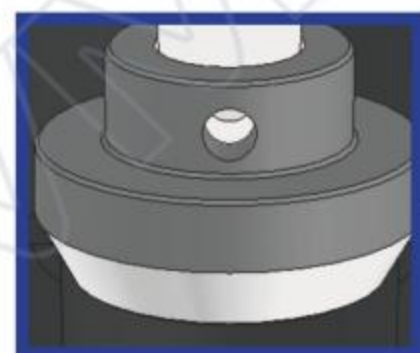

- Conical disc or other customized disc

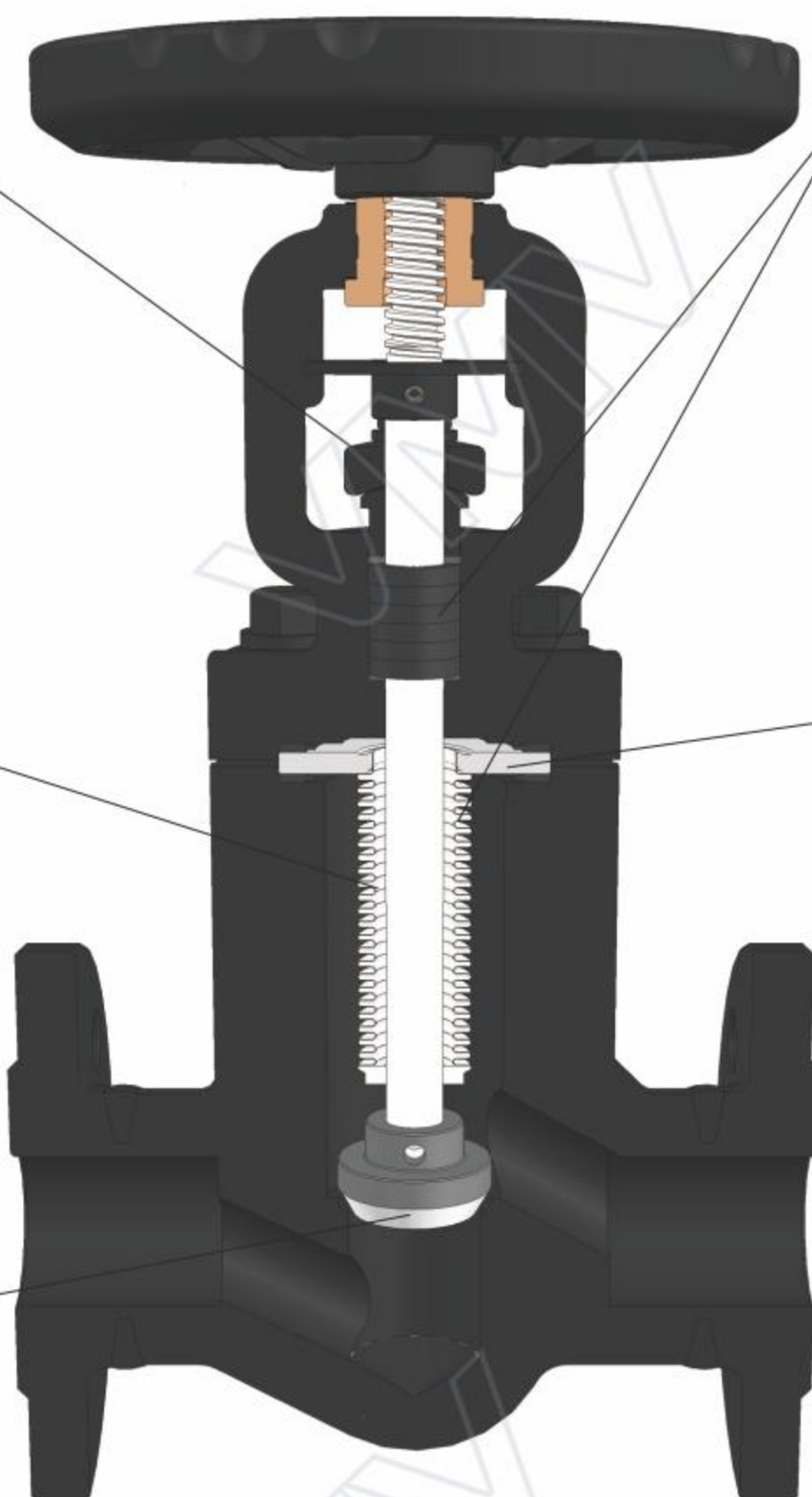

- Double seal design (bellows+packing)



- Sealing bowl with stainless steel
- Welded with bellows
- Ensure zero leakage



- Throttle disc with streamlined design Flow adjustment function
- Improve the resistance of water hammer

Application

Industry	Heating	Industrial Chemistry	Electricity	Pharmacy	Food	Tobacco	Printing	Air Conditioning	Shipbuilding
Medium	Steam	Thermal Oil	Ammonia Gas	Liquid Ammonia	Ethylene Glycol	Fatty Acid	Gases	Precious Fluids	Etc....

Main Part Materials

Name	Material
Body	A105、F304、F316、F316L、LF2
Seat	13Cr、SS304、SS316、Stellite
Disc	13Cr、F304、F316、Stellite
Bellows	SS304、SS316L
Stem	20Cr13、F304、F316
Bonnet	WCB、CF8、CF8M、CF3M、LCB

Performance Table

Nominal Pressure		PN(MPa)
Test Pressure	Shell Test	1.5 × Pr
	Sealing Test	1.1 × Pr
	Air Test	0.6
	Bellows Assembly Test	1.5 × Pr

Suitable Temp -196°C~600°C

Note: Pr is the pressure rating of the material at room temperature, the unit is MPa

Selection and Application

According to the performance of the medium, temperature, pressure, flow rate, and other characteristics combined with the process, operation, safety and other factors, select the corresponding valve specifications.



FORGED STEEL BELLOWS SEALED GLOBE VALVE

INTERGRAL FORGED STEEL BELLOWS SEALED GLOBE VALVE

Product Advantage

- Bellows seal element. The key part metal bellows is the connection part between bonnet and stem by automatic roll welding. The metal bellows can keep the stem part zero leakage.
- Benefited from the cone and streamline shape design, the disc has reliable sealing performance and longer service life.

- Double seal design (bellows + packing). Bellow and packing can prevent from leakage and provide excellent sealing performance.
- Grease nipple. It can directly lubricate the stem, nut and sleeve.
- Ergonomic hand wheel. It provides longer service life and easier operation.

Specifications

- Design standard: JB/T7746, API602
- Face to face dimension: EN558, ASME B16.10
- Flange ends: EN1092-1, ASME B16.5
- BW ends: ASME B16.25
- SW ends: ASME B16.11
- Test & inspection: EN12266, API598

Application

Thermal oil, Steam, Hot and cold water, Fatty acids, Ammonia, Natural gas, etc.

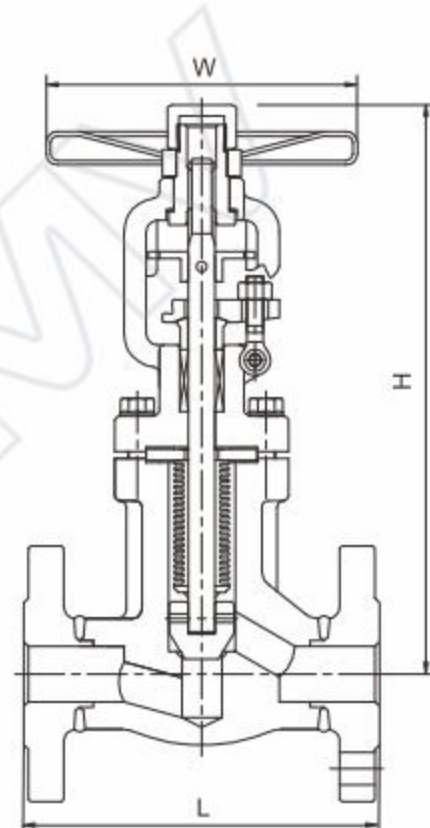

Data Dimension Table

DN	RF PN16-PN40 (150-600LB)			SW PN16-PN40 (150-600LB)		
	L	W	H≈	L	W	H≈
15	130	Φ140	255	79	Φ140	255
20	150	Φ140	255	92	Φ140	255
25	160	Φ160	261	111	Φ160	261
32	180	Φ160	261	120	Φ160	261
40	200	Φ180	325	152	Φ180	325
50	230	Φ200	348	172	Φ200	348

Product Advantage

- VMV NEW MOLD intergral forged flange, the flange and the valve body are hot-forged together.
- Full bore design, meet API602 standards.
- Compact material, stable structure and high strength performance make the shell never leak

- It has a switch indicating mark for easy site management.
- Compact structure, suitable for small space installation.
- Double seal design with bellows and packing makes sealing performance more better.

Specifications

- Design standard: API602
- Face to face dimension: EN558
- Flange ends: EN1092-1
- Test & inspection: EN12266

Application

Thermal oil, Steam, Hot and cold water, Fatty acids, Ammonia, Natural gas, etc.

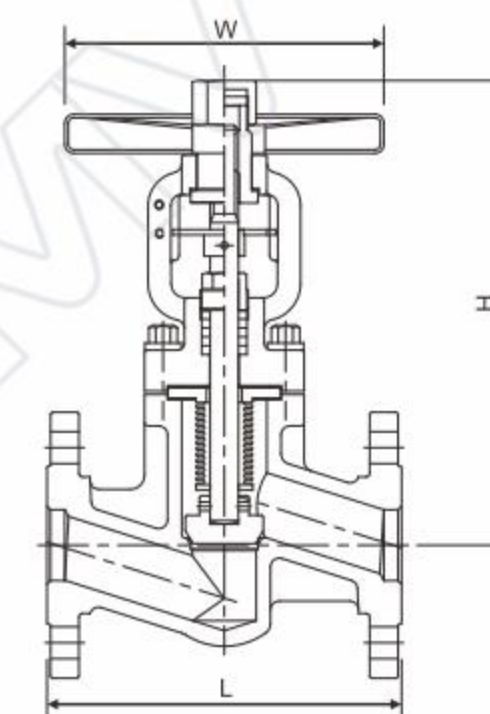

Data Dimension Table

DN	PN16			PN25			PN40		
	L	W	H≈	L	W	H≈	L	W	H≈
15	130	Φ140	213	130	Φ140	213	130	Φ140	213
20	150	Φ140	213	150	Φ140	213	150	Φ140	213
25	160	Φ160	227	160	Φ160	227	160	Φ160	227
32	180	Φ160	240	180	Φ160	240	180	Φ160	240
40	200	Φ180	272	200	Φ180	272	200	Φ180	272

FORGED STEEL BELLOWS SEALED GLOBE VALVE

FOR HIGH TEMPERATURE AND HIGH PRESSURE

FORGED STEEL BELLOWS SEALED GATE VALVE

Product Advantage

- Combined with the advantages of pressure self-sealing valves and bellows valves, stable performance even under high temperature and pressure.
- The higher the medium pressure, the greater the upward thrust of the middle part, and the better the sealing effect of the middle part.

- The connection between the valve body and bonnet adopts the pressure self-sealing structure, the wedge-shaped sealing ring and the four-open ring combination, so that the sealing ring deforms under high pressure to achieve reliable sealing, the higher the pressure, the more reliable the sealing.
- Better stuffing box design and valve stem reverse seal design.

Specifications

- Design standard: ASME B16.34
- Face to face dimension: ASME B16.10
- Flange ends: ASME B16.5
- BW ends: ASME B16.25
- Test & Inspection: API598

Application

Flammable and explosive, High temperature and high pressure, Toxic, Strong permeability and radioactivity, Valuable high purity media etc.

Data Dimension Table

DN	900LB Flange End						900LB Butt weld end		
	L	D	D1	D2	b	f	L1	Do	do
65	422	245	190.5	137	41.5	7.9	254	75	Acc to the working condition
80	384	240	190.5	156	38.5	7.9	305	91	
100	460	290	235.0	181	44.5	7.9	356	117	
150	613	380	317.5	241	56	7.9	508	172	
200	740	470	393.7	308	63.5	7.9	660	223	
DN	1500LB Flange End						1500LB Butt weld end		
	L	D	D1	D2	b	f	L1	Do	do
65	422	245	190.5	137	41.5	7.9	254	75	Acc to the working condition
80	473	265	203.2	168	48	7.9	305	91	
100	549	310	241.3	194	54	7.9	406	117	
150	711	395	317.5	248	83	9.6	559	172	
200	842	485	393.7	318	92	11.1	711	223	

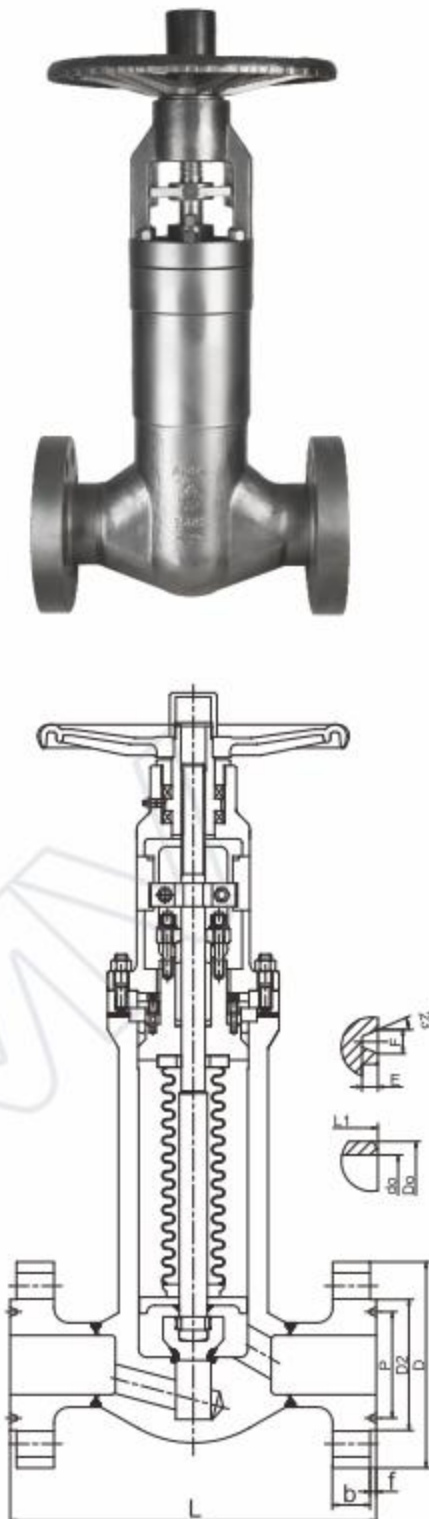

Product Advantage

- Bellows sealed gate valve with forged steel has a more stabilized structure, better density, better strength and small dimensional error.
- Better performance of strength and stress. Longer service life even in places where stress and crystal corrosion are severe.

- Double seal design (bellows + packing) to meet better sealing performance.
- The valve adopts steel integral martensitic stainless steel gate, with austenitic stainless steel seat, wear resistance and corrosion resistance, has better sealing.

Specifications

- Design standard: EN12516, API602
- Face to face dimension: EN558, ASME B16.10
- Flange ends: EN1092-1, ASME B16.5
- BW ends: ASME B16.25
- SW ends: ASME B16.11
- Test & inspection: EN12266, API598

Application

Thermal oil, Steam, Hot and cold water, Fatty acids, Ammonia, Natural gas, etc.

Data Dimension Table

DN	RF PN16-PN40			SW PN16-PN40 (150-800LB)		
	L	W	H≈	L	W	H≈
15	130	Φ95	210	79	Φ95	210
20	150	Φ95	215	92	Φ95	215
25	160	Φ117	245	111	Φ117	245
32	180	Φ145	280	120	Φ145	280
40	200	Φ145	295	120	Φ145	295
50	230	Φ170	363	140	Φ170	363

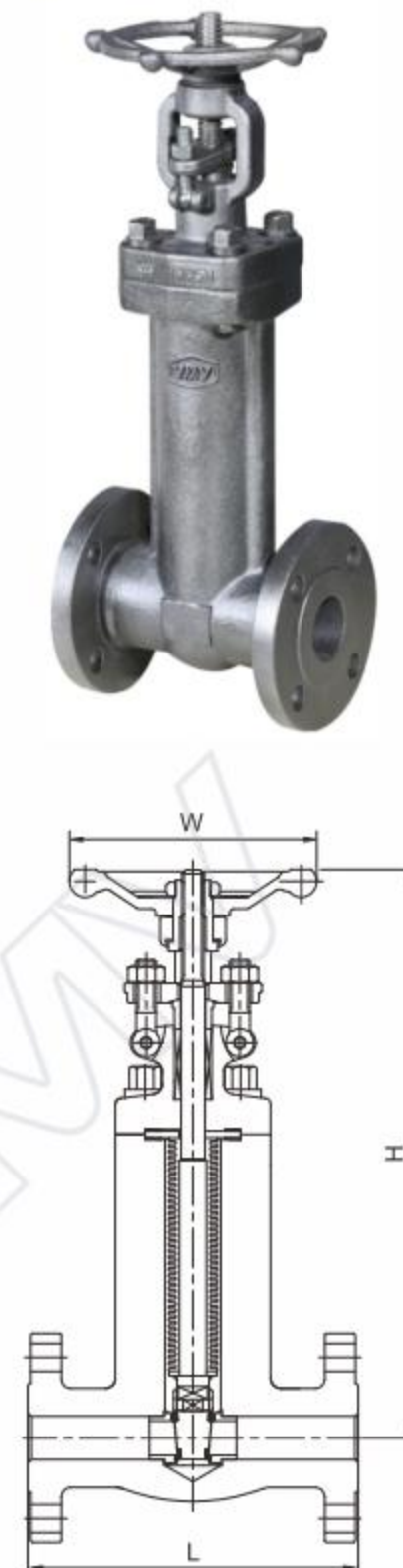

LOW TEMPERATURE BELLOWS GATE VALVE

BELLOWS SEALED MOLTEN SALT GLOBE VALVE

Product Advantage

- Double seal design with bellows and packing makes the seal at the valve stem more secure.
- The extended bonnet design the temperature of packing above 0°C, the packing and gasket meet ISO15848-1 Class A standards.
- Valve channel safety protection design to prevent abnormal pressure rise in the channel.

- Oil ban and degreasing, UV detection, high cleanliness of the inner cavity.
- Suitable for low temperature conditions, can be set according to customer requirements of low temperature isolation drip tray to prevent the valve stem packing freeze.

Specifications

- Design standard:API602
- Face to face dimension:ASME B16.10
- Flange ends:ASME B16.5
- Test & Inspection:API 598

Application

Suitable for polysilicon, Silane gas, Low temperature media, etc.

Product Advantage

- The bellows sealed molten salt globe valve is suitable for energy storage projects of photothermal power generation. Direct flow channel design. With better flow capacity and minimize pressure loss.
- Heat-resistant and high-strength stainless steel material. Suitable for high temperature environment of molten salt pipeline.
- High temperature resistant and low leakage packing and gasket. Meets ISO15848-1 Class A standard.

- Heat tracing device. Prevent condensation of molten salt from damaging the bellows.
- Bolt self-compensation structure. Suitable for temperature fluctuation conditions.
- Photothermal power generation and energy storage projects, Binary molten salt, Ternary molten salt, etc.

Specifications

- Design standard:API602, ASME B16.34
- Face to face dimension:ASME B16.10
- Flange ends:ASME B16.25
- Test & Inspection:API 598

Application

Suitable for solar thermal power generation and energy storage projects, binary molten salt, ternary molten salt

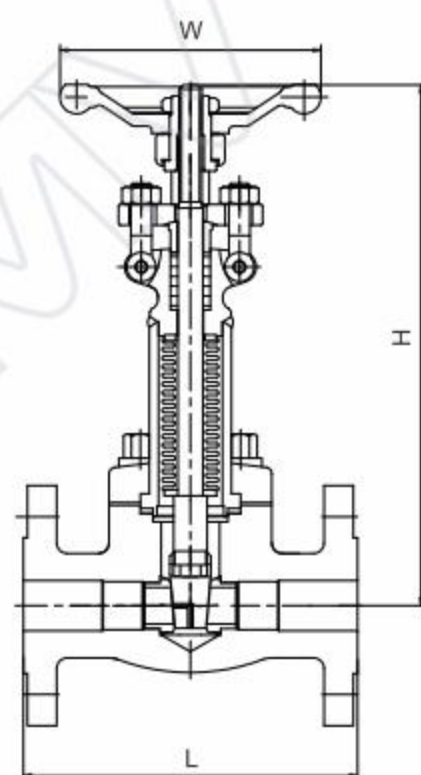

Data Dimension Table

NPS	150LB			300LB			600LB		
	L	W	H≈	L	W	H≈	L	W	H≈
1/2 "	108	Φ95	225	140	Φ95	225	165	Φ95	225
3/4 "	117	Φ95	233	152	Φ95	233	190	Φ95	233
1	127	Φ117	268	165	Φ117	268	216	Φ117	268
1 1/4	140	Φ145	310	178	Φ145	310	229	Φ145	310
1 1/2	165	Φ145	330	190	Φ145	330	241	Φ145	330
2 "	178	Φ200	515	216	Φ200	535	292	Φ200	565
2 1/2	191	Φ200	595	241	Φ200	610	330	Φ250	645
3 "	203	Φ250	665	283	Φ250	690	356	Φ250	710
4 "	229	Φ280	800	305	Φ300	820	432	Φ300	890
5 "	254	Φ300	910	381	Φ300	940	508	Φ400	1020
6 "	267	Φ300	1040	403	Φ350	1070	559	Φ450	1190
8 "	292	Φ350	1310	419	Φ400	1360	660	Φ500	1490
10 "	330	Φ400	1710	457	Φ450	1800	787	Φ600	1820
12 "	356	Φ450	2030	502	Φ500	2180	838	Φ680	2210
14 "	381	Φ500	2300	762	Φ550	2380	889	Φ600	2450
16 "	406	Φ550	2580	838	Φ600	2650	991	Φ600	2800

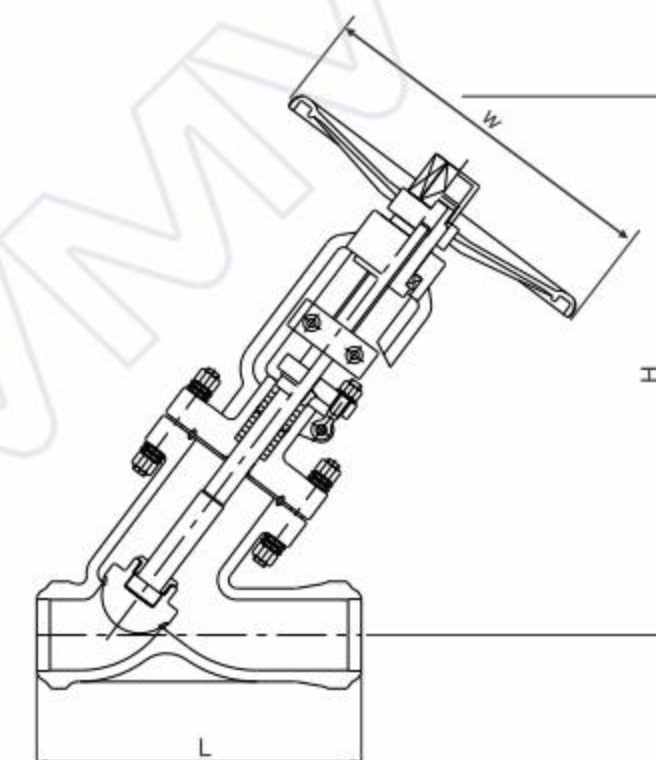
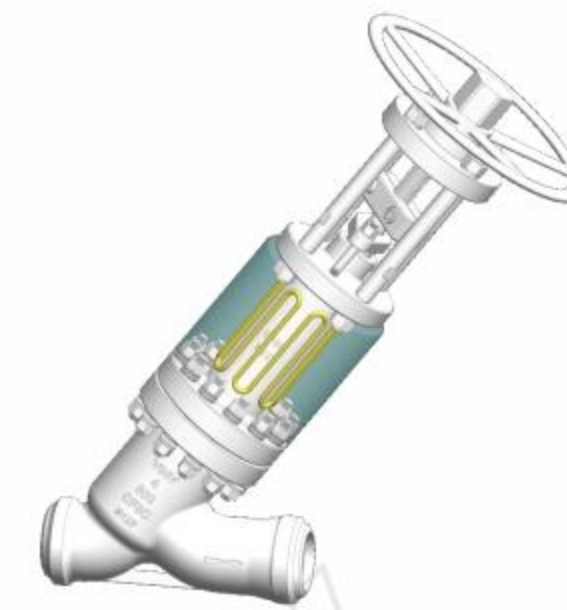

Data Dimension Table

DN	150LB		300LB		600LB	
	L	W	L	W	L	W
1 "	120	Φ160	120	Φ160	120	Φ160
1 1/2	140	Φ180	140	Φ180	140	Φ180
2 "	170	Φ200	170	Φ200	170	Φ200
2 1/2	216	Φ220	292	Φ250	330	Φ250
3 "	243	Φ250	318	Φ250	356	Φ350
4 "	292	Φ300	356	Φ350	432	Φ400
5 "	356	Φ350	400	Φ400	508	Φ500
6 "	406	Φ350	445	Φ400	559	Φ550
8 "	495	Φ400	559	Φ500	660	Φ600

DN	PN40		PN63		PN100	
	L	W	L	W	L	W
25	120	Φ160	120	Φ160	120	Φ160
40	140	Φ180	140	Φ180	140	Φ180
50	170	Φ200	170	Φ200	170	Φ200
65	290	Φ250	340	Φ250	340	Φ250
80	310	Φ250	380	Φ300	380	Φ350
100	350	Φ300	430	Φ350	430	Φ400
125	400	Φ350	500	Φ450	500	Φ450
150	480	Φ400	550	Φ500	550	Φ500
200	600	Φ550	650	Φ550	650	Φ600

DIN STANDARD LIFT CHECK VALVE

DIN STANDARD LIFT CHECK VALVE



- Cylindrical compression spring.
- Precise resetting elasticity, strong corrosion resistance

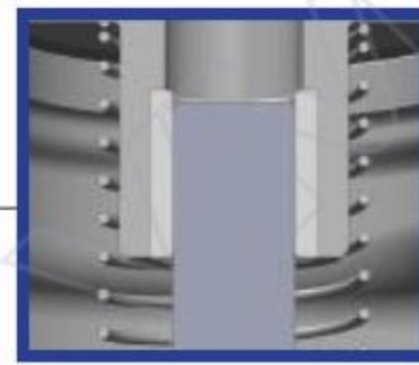

- Stainless steel guide sleeve can limit its position
- Wear and corrosion resistance



- German coated sand casting
- Surface finish: 12.5~25 microns

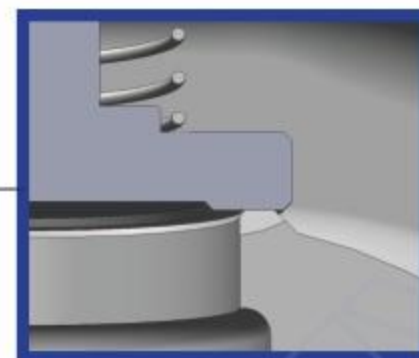
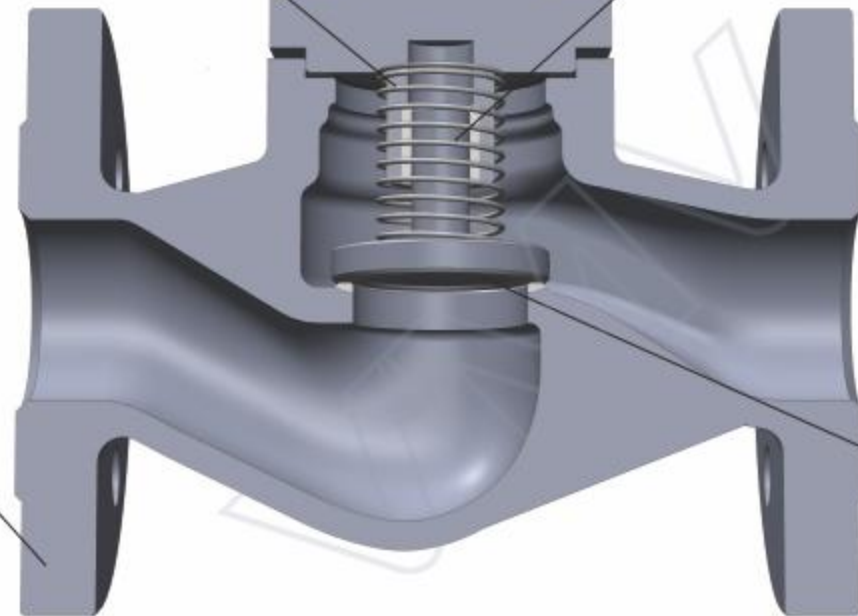

- Sealing surface is wear-resistant and corrosion-resistant

Main Part Materials

Name	Material
Body	GS-C25, CF8, CF8M, CF3M
Seat	13Cr, SS304, SS316, Stellite
Disc	13Cr, F304, F316, Stellite
Spring	SS304, SS316L
Sleeve	13Cr, SS304, Copper alloy
Bonnet	GS-C25, CF8, CF8M, CF3M

Performance Table

Nominal Pressure		PN(MPa)
Test Pressure	Shell Test	1.5 × Pr
	Sealing Test	1.1 × Pr
	Air Test	0.6
	Bellows Assembly Test	1.5 × Pr
Suitable Temp	-196°C~600°C	
Note: Pr is the pressure rating of the material at room temperature, the unit is MPa		

Product Advantage

- Lift check valve is self sealing valve. The disc can be acted by the flow which can avoid against the media flow back.
- The disc with stainless steel spring can keep the valve work in any direction.
- The sealing surface is wear resistance, corrosion resistance and long service life.

- Reasonable structure, reliable sealing, excellent performance and attractive appearance.

Specifications

- Design standard: EN12516
- Face to face dimension: EN558
- Flange ends: EN1092-1
- Test & inspection: EN12266

Application

Thermal oil, Steam, Hot and cold water, Fatty acids, Ammonia, Natural gas, etc.

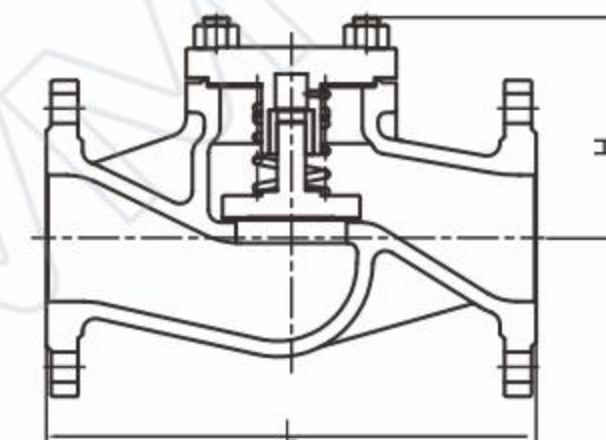

Data Dimension Table

DN	PN16		PN25		PN40	
	L	H≈	L	H≈	L	H≈
15	130	78	130	78	130	78
20	150	82	150	82	150	82
25	160	91	160	91	160	91
32	180	95	180	95	180	95
40	200	101	200	101	200	101
50	230	109	230	109	230	109
65	290	119	290	119	290	119
80	310	139	310	139	310	139
100	350	155	350	155	350	155
125	400	192	400	192	400	192
150	480	220	480	220	480	220
200	600	303	600	303	600	303
250	730	346	730	346	730	346
300	850	387	850	387	850	387
350	980	441	980	441	980	441
400	1100	570	1100	570	1100	570

DIN STANDARD Y STRAINER

DIN STANDARD Y STRAINER

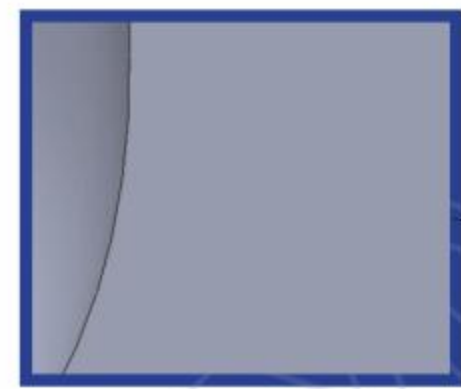

• German coated sand casting
• Surface finish: 12.5~25 microns



• Drain plug design (If need)

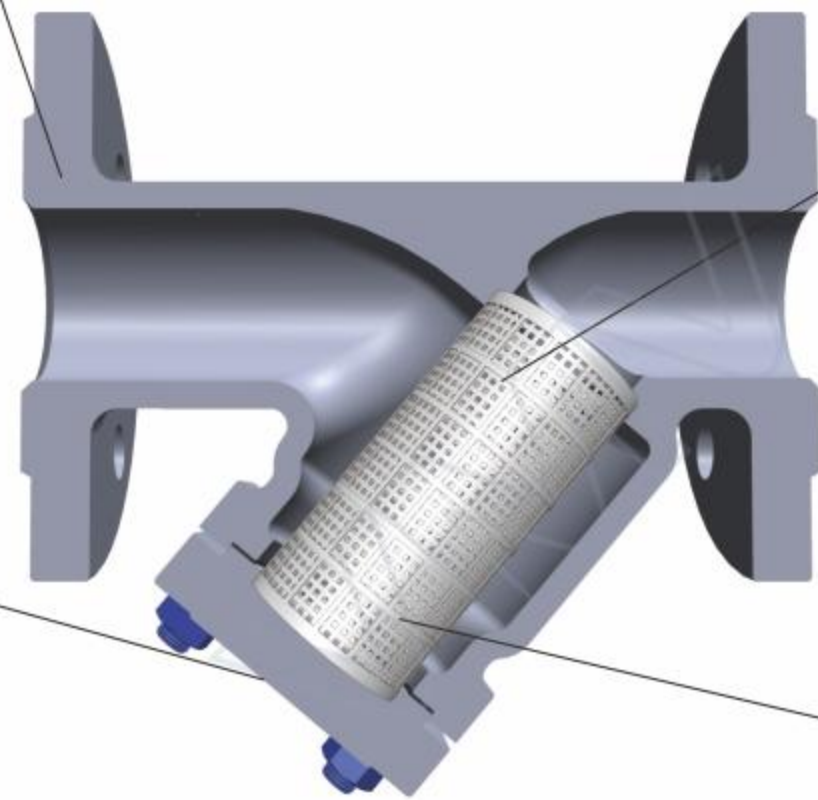

• **Filter Mesh**
Water: 20-40
Gas: 40-100
Oil: 10-120



• Filter screen can be removed and cleaned



• Filter screen with Single or double layer

Product Advantage

- VMV New Model
- Intergral Forged Steel Y Strainer
- Cast Steel Y Strainer
- Y Strainer is used to separate the impurity of media. It can protect the normal use of valves and equipment.

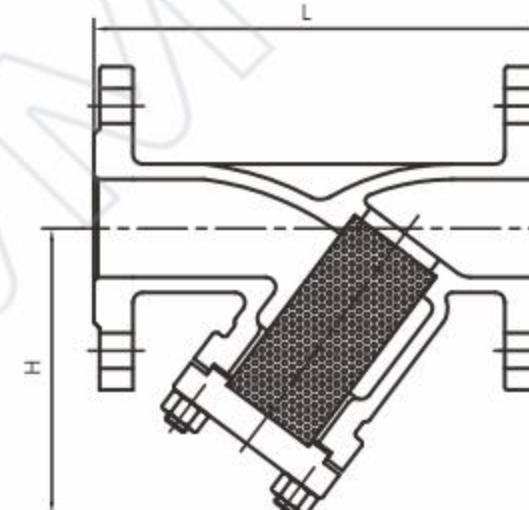

Specifications

- Design standard: EN12516
- Face to face dimension: EN558
- Flange ends: EN1092-1
- Test & inspection: EN12266

Application

Thermal oil, Steam, Hot and cold water, Fatty acids, Ammonia, Natural gas, etc.

Data Dimension Table

DN	PN16		PN25		PN40	
	L	H	L	H	L	H
15	130	90	130	90	130	90
20	150	97	150	97	150	97
25	160	110	160	110	160	110
32	180	113	180	113	180	113
40	200	138	200	138	200	138
50	230	147	230	147	230	147
65	290	170	290	170	290	170
80	310	204	310	204	310	204
100	350	240	350	240	350	240
125	400	288	400	288	400	288
150	480	334	480	334	480	334
200	600	398	600	398	600	398
250	730	590	730	590	730	590
300	850	596	850	596	850	596

Main Part Materials

Name	Material
Body	JS1049, GS-C25, CF8, CF8M, CF3M
Screen	SS304, SS316
Gasket	Flexible graphite+stainless steel, PTFE
Bonnet	JS1049, GS-C25, CF8, CF8M, CF3M
Nut	ASTM A194-2H, A194-8
Bolt	ASTM A193-B7, A193-B8

Performance Table

Nominal Pressure		PN(MPa)
Test Pressure	Shell Test	1.5 × Pr
	Sealing Test	1.1 × Pr
	Air Test	0.6
	Bellows Assembly Test	1.5 × Pr
Suitable Temp	-196°C~600°C	
Note: Pr is the pressure rating of the material at room temperature, the unit is MPa		

DIMENSIONS OF FLANGE CONNECTIONS

DIMENSIONS OF FLANGE CONNECTIONS

DIN Standard Dimensions

DN	PN16						PN25					
	D	D1	D2	b	f	n-Φd	D	D1	D2	b	f	n-Φd
15	95	65	45	16	2	4-Φ14	95	65	45	16	2	4-Φ14
20	105	75	58	18	2	4-Φ14	105	75	58	18	2	4-Φ14
25	115	85	68	18	2	4-Φ14	115	85	68	18	2	4-Φ14
32	140	100	78	18	2	4-Φ18	140	100	78	18	2	4-Φ18
40	150	110	88	18	3	4-Φ18	150	110	88	18	3	4-Φ18
50	165	125	102	18	3	4-Φ18	165	125	102	20	3	4-Φ18
65	185	145	122	18	3	4-Φ18	185	145	122	22	3	8-Φ18
80	200	160	138	20	3	8-Φ18	200	160	138	24	3	8-Φ18
100	220	180	158	20	3	8-Φ18	235	190	162	24	3	8-Φ22
125	250	210	188	22	3	8-Φ18	270	220	188	26	3	8-Φ26
150	285	240	212	22	3	8-Φ22	300	250	218	28	3	8-Φ26
200	340	295	268	24	3	12-Φ22	360	310	278	30	3	12-Φ26
250	405	355	320	26	3	12-Φ26	425	370	335	32	3	12-Φ30
300	460	410	378	28	4	12-Φ26	485	430	395	34	4	16-Φ30
350	520	470	438	30	4	16-Φ26	555	490	450	38	4	16-Φ33
400	580	525	490	32	4	16-Φ30	620	550	505	40	4	16-Φ36

DN	PN40					
	D	D1	D2	b	f	n-Φd
15	95	65	45	16	2	4-Φ14
20	105	75	58	18	2	4-Φ14
25	115	85	68	18	2	4-Φ14
32	140	100	78	18	2	4-Φ18
40	150	110	88	18	3	4-Φ18
50	165	125	102	20	3	4-Φ18
65	185	145	122	22	3	8-Φ18
80	200	160	138	24	3	8-Φ18
100	235	190	162	24	3	8-Φ22
125	270	220	188	26	3	8-Φ26
150	300	250	218	28	3	8-Φ26
200	375	320	285	34	3	12-Φ30
250	450	385	345	38	3	12-Φ33
300	515	450	410	42	4	16-Φ33
350	580	510	465	46	4	16-Φ36
400	660	585	535	50	4	16-Φ39

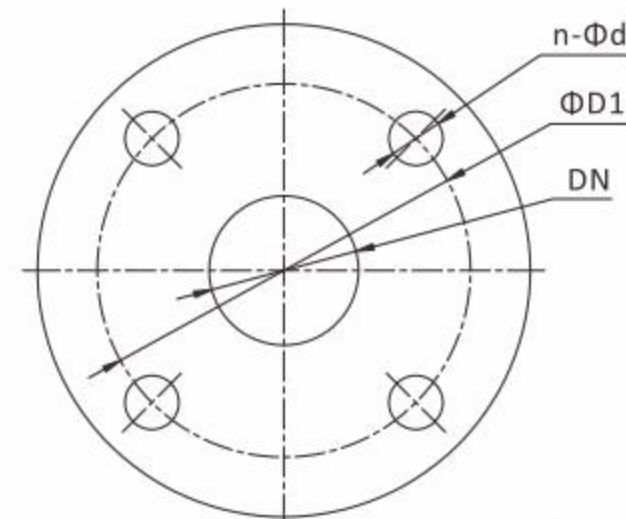
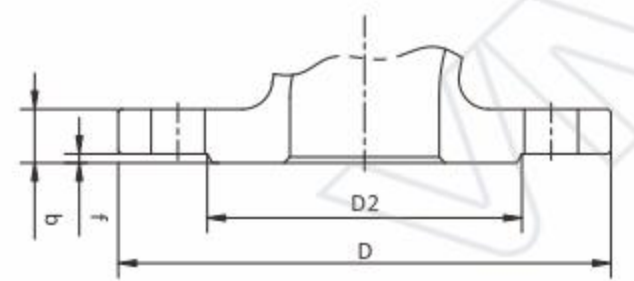

ANSI Standard Dimensions

DN	150Lb						300Lb					
	D	D1	D2	b	f	n-Φd	D	D1	D2	b	f	n-Φd
1/2 "	90	60.3	35	10	2	4-Φ16	95	66.7	35	14.7	2	4-Φ16
3/4 "	100	69.9	43	10.9	2	4-Φ16	115	82.6	43	16.3	2	4-Φ19
1 "	110	79.4	51	11.6	2	4-Φ16	125	88.9	51	17.9	2	4-Φ19
1 1/4 "	115	88.9	63.5	13.2	2	4-Φ16	135	98.4	63.5	19.5	2	4-Φ19
1 1/2 "	125	98.4	73	14.7	2	4-Φ16	155	114.3	73	21.1	2	4-Φ22
2 "	150	120.7	92	16.3	2	4-Φ19	165	127	92	22.7	2	8-Φ19
2 1/2 "	180	139.7	105	17.9	2	4-Φ19	190	149.2	105	25.9	2	8-Φ22
3 "	190	152.4	127	19.5	2	4-Φ19	210	168.3	127	29	2	8-Φ22
4 "	230	190.5	157	24.3	2	8-Φ19	255	200	157	32.2	2	8-Φ22
5 "	255	215.9	186	24.3	2	8-Φ22	280	235	186	35.4	2	8-Φ22
6 "	280	241.3	216	25.9	2	8-Φ22	320	269.9	216	37	2	12-Φ22
8 "	345	298.5	270	29	2	8-Φ22	380	330.2	270	41.7	2	12-Φ26
10 "	405	362	324	30.6	2	12-Φ26	445	387.4	324	48.1	2	16-Φ29
12 "	485	431.8	381	32.2	2	12-Φ26	520	450.8	381	51.3	2	16-Φ32
14 "	535	476.3	413	35.4	2	12-Φ29	585	514.4	413	54.4	2	20-Φ32
16 "	595	539.8	470	37	2	16-Φ29	650	571.5	470	57.6	2	20-Φ35
18 "	635	577.9	533	40.1	2	16-Φ32	710	628.6	533	60.8	2	24-Φ35
20 "	700	635	584	43.3	2	20-Φ32	775	685.8	584	64	2	24-Φ35

JIS Standard Dimensions

DN	10K						20K					
	D	D1	D2	b	f	n-Φd	D	D1	D2	b	f	n-Φd
15A	95	70	51	12	1	4-Φ15	95	70	51	14	1	4-Φ15
20A	100	75	56	14	1	4-Φ15	100	75	56	16	1	4-Φ15
25A	125	90	67	14	1	4-Φ19	125	90	67	16	1	4-Φ19
32A	135	100	76	16	2	4-Φ19	135	100	76	18	2	4-Φ19
40A	140	105	81	16	2	4-Φ19	140	105	81	18	2	4-Φ19
50A	155	120	96	16	2	4-Φ19	155	120	96	18	2	8-Φ19
65A	175	140	116	18	2	4-Φ19	175	140	116	20	2	8-Φ19
80A	185	150	126	18	2	8-Φ19	200	160	132	22	2	8-Φ23
100A	210	175	151	18	2	8-Φ19	225	185	160	24	2	8-Φ23
125A	250	210	182	20	2	8-Φ23	270	225	195	26	2	8-Φ25
150A	280	240	212	22	2	8-Φ23	305	260	230	28	2	12-Φ25
200A	330	290	262	22	2	12-Φ23	350	305	275	30	2	12-Φ25
250A	400	355	324	24	2	12-Φ25	430	380	345	34	2	12-Φ27
300A	445	400	368	24	3	16-Φ25	480	430	395	36	3	16-Φ27

CUSTOMIZED BELLOWS VALVE

CUSTOMIZED BELLOWS VALVE

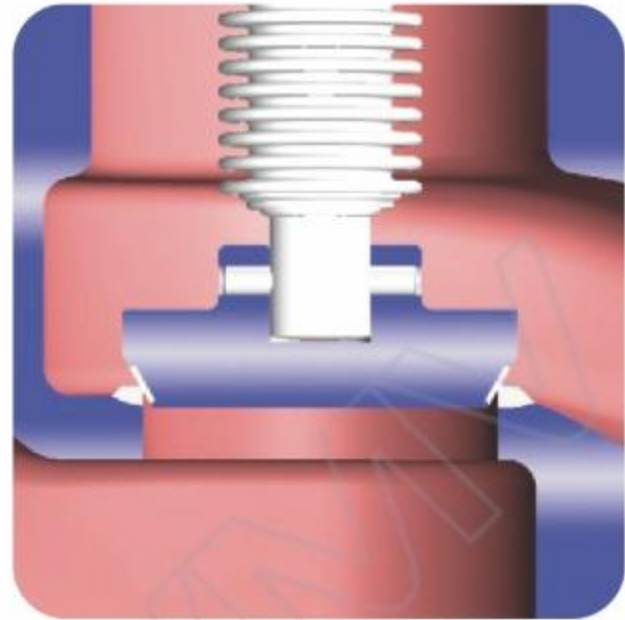

1. Conical sealing surface will remove impurity automatically.

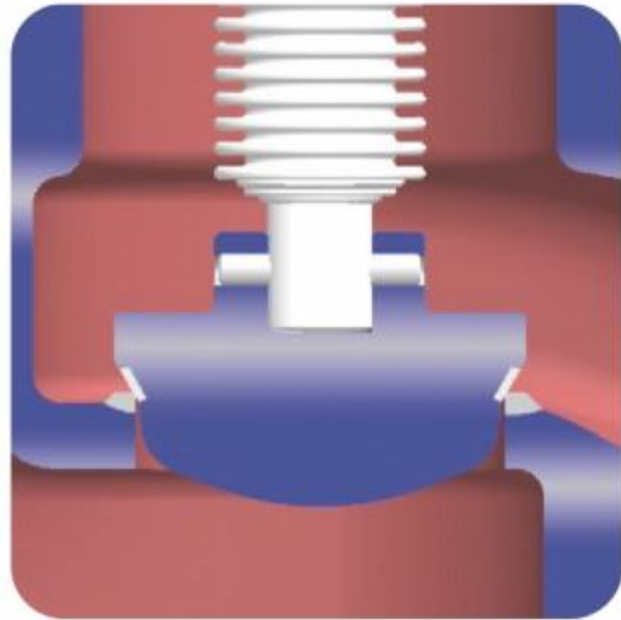

2. Streamline design disc has better tolerance to water hammer.

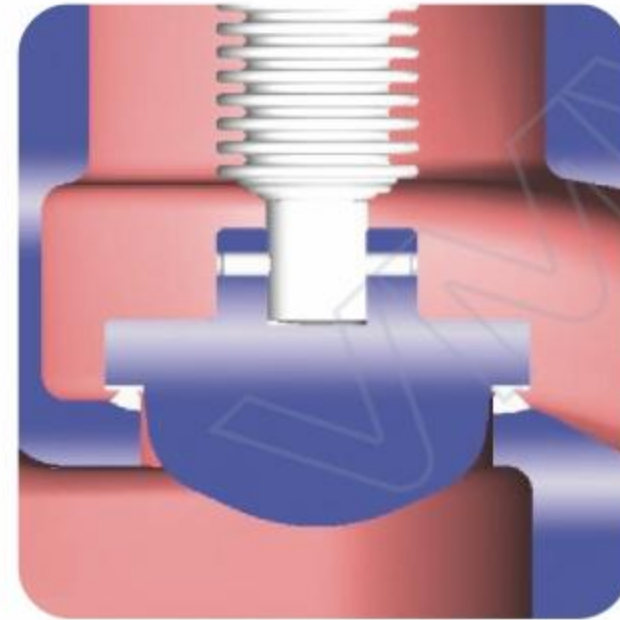

3. Flat sealing surface and streamline disc with better tolerance to water hammer, and can be installed in any position.

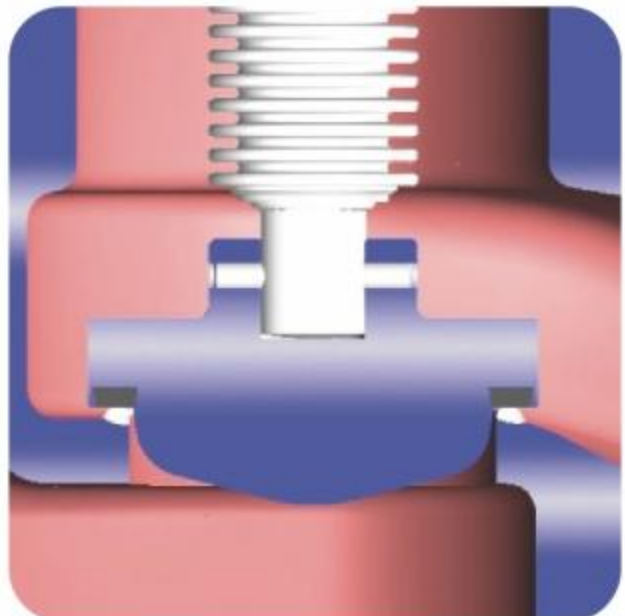

4. Soft sealing surface can prevent sparks when opening and closing. Streamline disc can regulate flow rate.

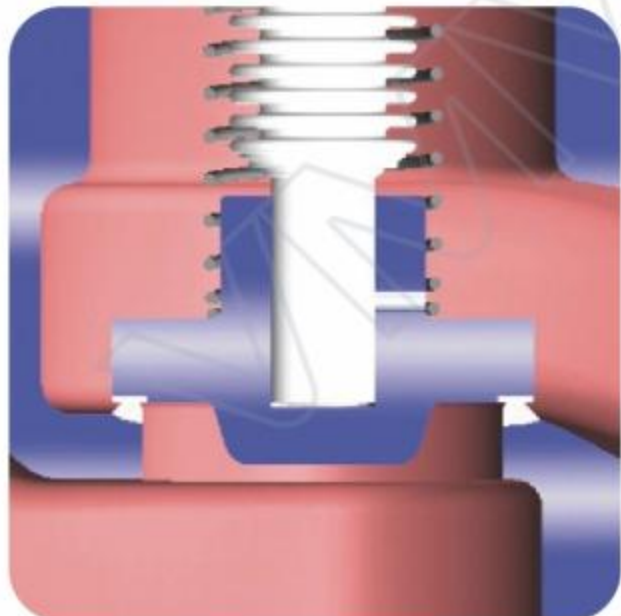

5. Globe-check disc with spring, it can be installed in any position.

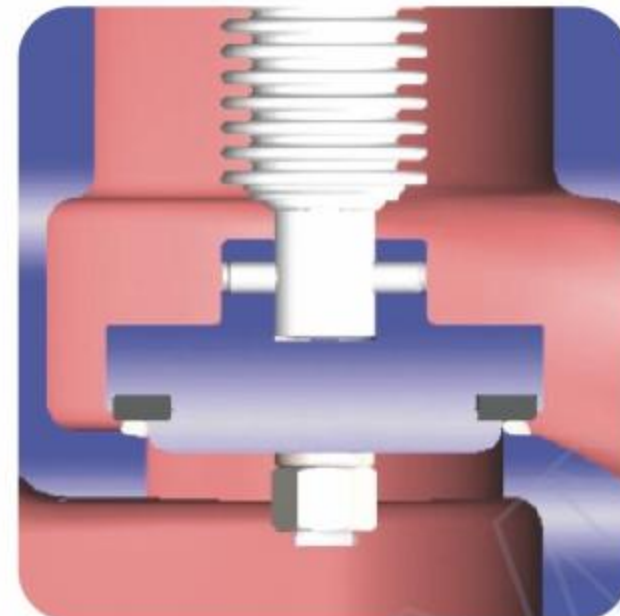

6. Soft sealing surface can prevent sparks, and easy for replacement.

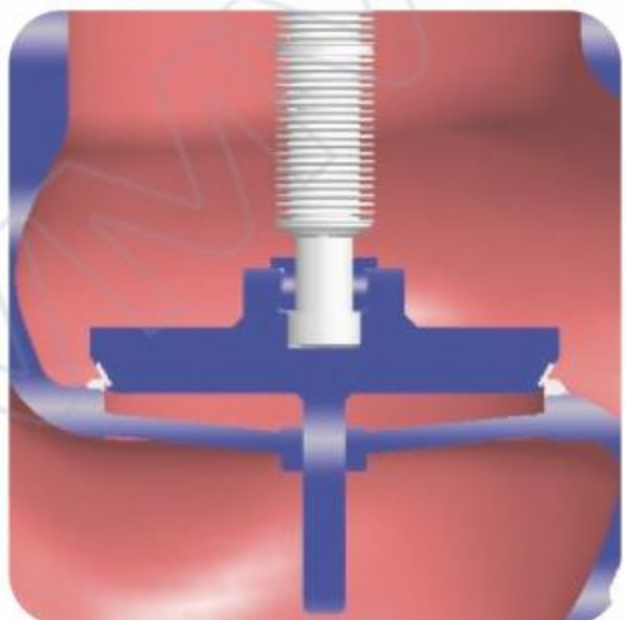

7. Central locate structure is good for sealing and lower noise.

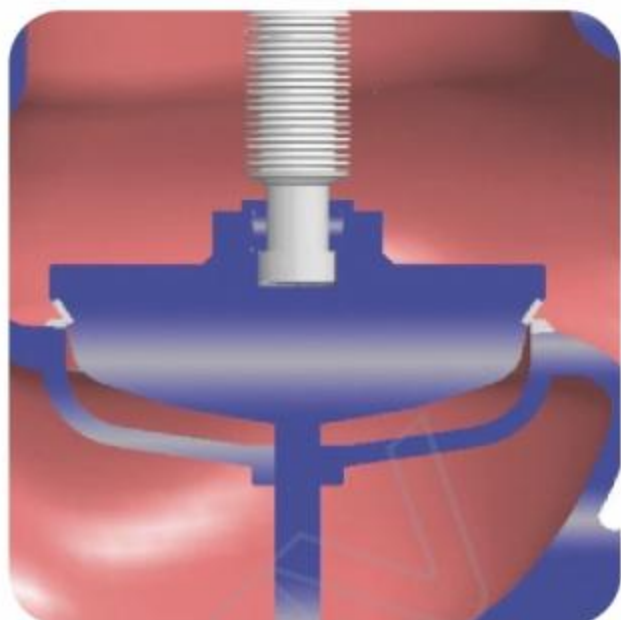

8. Streamline disc with central locate structure can prevent water hammer and lower noise.

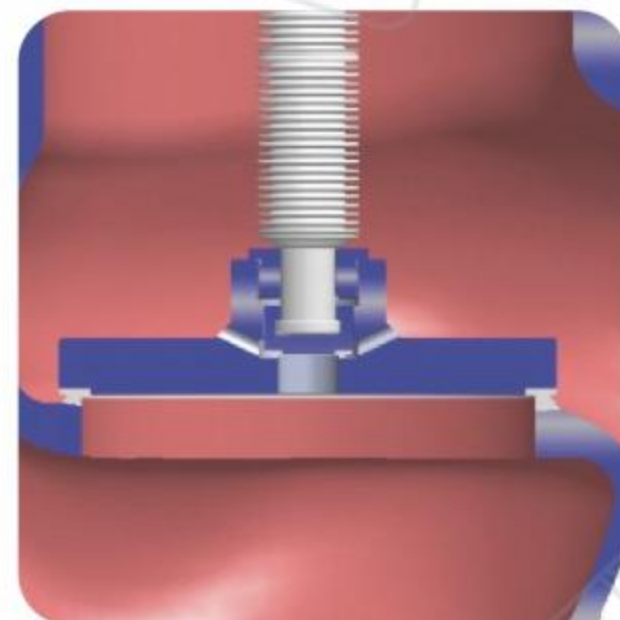

9. Double disc design, the second disc can relieve pressure and easy for opening and closing.

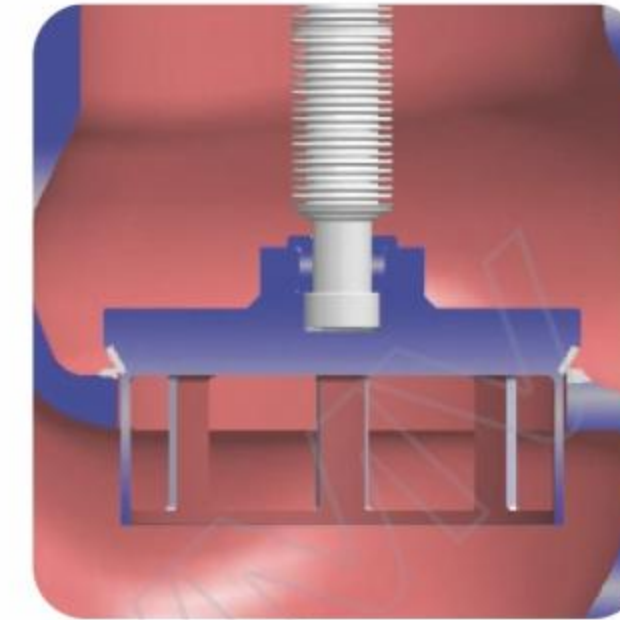

10. Window shape regulating disc, control the flow rate precisely.

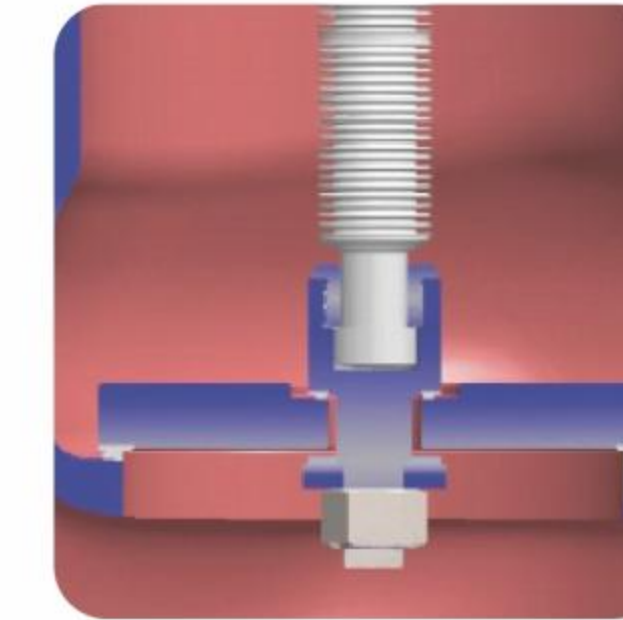

11. Balance disc design which easy for opening and usually applied for size DN150 and above.

Please confirm the detailed requirements as below

Working temperature : _____

Pressure : _____

Medium : _____

Body material : _____

Bellow material : _____

Other parts : _____

Others : _____

ZHEJIANG NEWTON FLUID CONTROL CO.,LTD.

Headquarters (Wenzhou)

Zhiyi road, Lingxia industrial zone, Wuniu, Wenzhou, Zhejiang, China.

Tel: 86-577-67978269

Fax: 86-577-67376711

E-mail: vmv@vmv-valve.com

Shanghai R&D Center

Jiading District, Shanghai
Building 12A, No. 1818 Chengbei Road

Tel: 86-18057752663

E-mail: vmv8@vmv-valve.com